

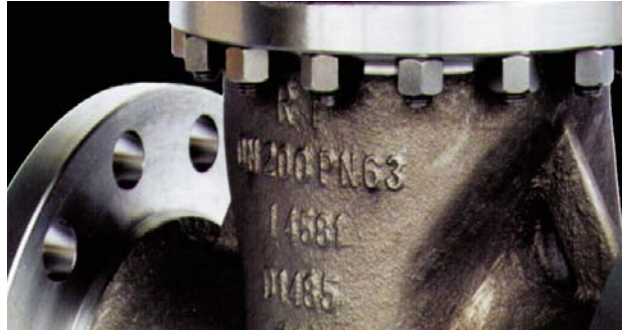

EN DIN



Gate Valves
Swing Check Valves

Contents

Contents	2	Fig. 266-566	30
Company Profile	3	Fig. 267-567	32
Engineering	4	Variants & Devices	34
Manufacturing	5	Swing Check Valves	36
Warehouse	6	Fig. 270-570	40
Testing & Checking	7	Fig. 280-580	42
Quality System	8	Fig. 290-590	44
Environment	9	Fig. 291-591	46
CE Mark	10	Fig. 296-596	48
Atex	11	Fig. 297-597	50
Gate Valves	12	Variants & Devices	52
Fig. 205-505	16	Handling & Stocking	53
Fig. 210-510	18	Safety Devices	54
Fig. 235-535	20	Sale & Delivery Conditions	56
Fig. 240-540	22	Product Guarantee	57
Fig. 250-550	24	Standard Comparison	58
Fig. 260-560	26	Photo Gallery	60
Fig. 261-561	28		

Company Profile

Since from his foundation in the year 1947, RT Valves have been producing valves for industrial applications.

The standard production range covers the sizes from DN 50 up to DN 1000 for pressure rating up to PN 320.

A long experience in making valve with the most advanced technologies guarantees a top quality product with a wide range of solutions for many different applications.

For these reasons, today, the valves produced by RT are widely used in chemical, petrochemical, food, gases, power generation, water treatment and distribution plants in many countries.

The design, experiment, manufacturing, and test of the products are done under one roof in strict accordance with the relevant national standards and engineering rules to ensure an easy installation, maintenance, replacing and as guaran-

tee of a high product quality and long durability.

The quality system established in RT is in compliance with the EN ISO 9001 standard and has been approved since the year 1993.

The company energies and resources have always been addressed to the research of new solutions and to the acquisition of most advanced technologies offered by the market, in order to achieve a constant evolution of the valve performance and quality. Project innovations, performances and confidence improvement, assurance and easy maintenance are criteria always applied in the production.

A special program for environmental protection guarantee the design and the manufacturing of products with the lowest impact for the environment obtainable with the technologies now available.



RT provides the complete design of all the products in his studios whit the most advanced technologies.

All the valves are accurately designed totally according to last editions of DIN, EN and ISO standards. With the new releases of reference standards the products are updated to meet the new requirements. A CAD - CAM system aid the technicians to develop the project and to produce the detailed drawings of the complete valve and subparts: RT, on request, can provide quickly to his customer all the drawings that they need. All the characteristics are obtained and verified with multiple calculation to reach the optimal performances.

A specific software developed according to the current engineering rules (DIN 3840 o EN 12516) allow the technicians to determine in advance the pressure effects on valves body: the stress and the forces generated are calculated to verify the material resistance in working conditions.

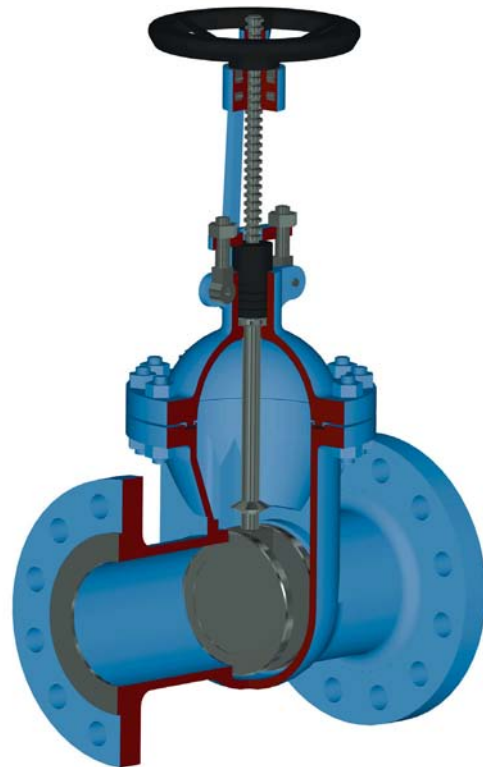

The prototype of a new product is subject to several and intensive test:

- the quality of the casting is verified whit X-ray and with magnetic particle or dye liquids, to determine if the heating method is correct and the final quality level is in compliance whit the requirements;
- the behaviour of the valve material is verified in standard working conditions during a long time period whit an intensive pressure test;
- the resistance of all valve components is verified in standard working conditions with multiple operations.

Manufacturing

RT makes his products on latest production equipment.

The CNC machines are used in making of both valve bodies and inner parts. This is a guarantee for an accurate and precise realisation in accordance with design characteristics and a perfect interchangeability and substitutability of all valve components.

These machining systems permit to reach the top quality of the products: the finish and the precision of machined surfaces are the best that can be obtained with latest technologies.

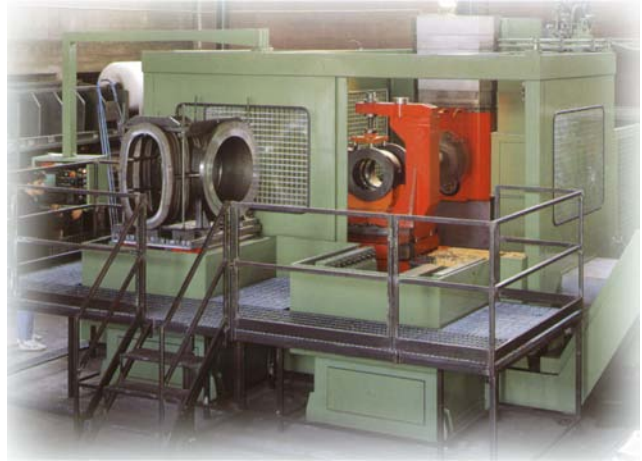

RT technicians survey with attention the assembly step to ensure that each component has no defects, each valve is correctly assembled, and the final product is totally in accordance with design characteristics.

Also the bolts tightening is performed in controlled condition: each bolt is tightened to the exactly required torque to guarantee the perfect tightness of the bolted connection. All RT technicians and workers are well qualified and experienced and guarantee together with up to date equipment a high and constant quality of the product.

The welding process is totally automated, to obtain the best quality of chemical and mechanical characteristics. Stainless steels, duplex, stellite, Monel, Hastelloy, Inconel and all other alloyed materials are overlay welded on the seats maintaining on the seats maintaining their characteristics of resistance to corrosion and temperature with the highest hardness.

The easy and quick assembly is the main target of all other steps: a short assembly time is also a guarantee for the customer of a low cost and easy maintenance.



Warehouse



In RT warehouse a big stock of raw materials and work in progress is stored. A large covered area is used only to store the materials.

All arriving goods are subject to rigid tests and controls according to Quality Assurance Manual to guarantee that no defective material shall be used in the production.

The stock level is constantly monitored and the acquired customer's orders are considered for the requirement of raw materials. The orders to the qualified suppliers are placed on the basis of MRP (Manufacturing Requirements Program) results produced by the data elaboration of the bill of materials, the minimum programmed stock levels and the suppliers standard delivery times.

The availability of raw material and the status of work in progress are updated every day with the orders received from the customers and the data from the production: in this way RT can inform the customer in each moment about the order situation, and can guarantee a punctual delivery. The raw materials are stored by appropriate methods to preserve their quality for a long time and their conditions and conservation are constantly monitored.

All the stored materials, after the inspections, are correctly identified to prevent an improper use. With these methods the traceability for each valve component and the related material certificates is guaranteed.



Testing & Checking

During the stages of manufacturing process, all components are subjected to rigid quality controls according to RT Quality Control Plans and DIN, EN and ISO applicable standards.

All completed valves, before leaving the factory have undergone to several tests on up to date equipment.

The testing equipment are regularly calibrated according to formal procedures with the reference to samples certified by official testing laboratories (Sit, Namas, etc.).

These equipment permits to RT technicians to perform all the required tests like dimensional checks, strength tests and tightness tests.

By these methods RT can guarantee that 100% of the valves delivered to the customers are completely in conformity with the requirements of Quality Control Plans and reference standards.



Apposite Quality Control Plans are predisposed for valves ordered for special applications (ex. gas, flammable fluids, etc.) or subject particular regulations (TRB, TRD, TRbF, etc.).

The know how of RT personnel employed in the tests is verified and certified by an independent authority according to the current regulations.

All the performed tests are certified according to EN 10204.

Quality System

RT has done of the total quality one of its firm missions. Since the year 1993 the Quality Assurance System have been certified according to EN ISO 9001 standards.

Well-qualified personnel are employed in each stage of the production process, from the reception of raw materials up to delivery of the products. Periodically the personnel are subjected to refresher courses and his technical capabilities are verified.

All the stored materials, after the inspections, are correctly identified to prevent an improper usage.

During the production the material identification and traceability is guaranteed by appropriate methods. The origin certificates of raw material are recorded to guarantee the traceability for each valve component. The goods conformity to the applicable standards and to the customer's technical specifications are guaranteed and certified according to EN 10204. The order situation, availability and the advancing state of work are brought up to date in real time.

The Quality System predisposed by RT is approved and certified by independent authorities also as suitable in the production of valves for special application like steam or dangerous fluids.

APPROVALS

Reference standard	Issuing body
ISO 9001:2000	TUV
AD 2000 – M. A4	TUV
AD 2000 – M. HP 0	TUV
PED	TUV



Environment

On request RT can supply valves certified by TUV in accordance with the new standard ISO 15848 and with directive TA-Luft 2002. The standard ISO 15848 fix restrictive limits for fugitive emissions from valve sealings to make possible to use these valves also with very dangerous or polluting fluids.

To meet these high performance requirements, these valves are provided with special sealings and additional devices expressly designed to limit the fugitive emissions.

The qualified range cover the diameters from DN 50 up to DN 800 and the pressure classes from PN 6 up to PN 100

These valves are available in three versions to meet the customer's needs in all possi-



Leak rate in helium test

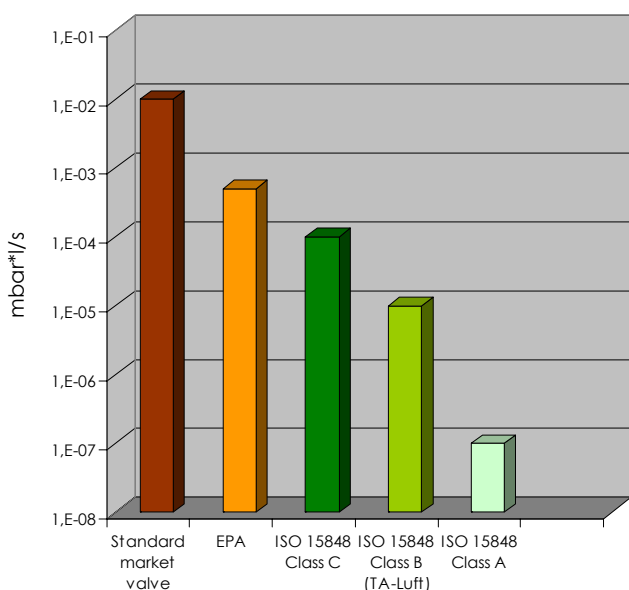

ble application ranges with three different performance levels according to ISO 15848 definitions

- AH - CO₂ - SS0 - RT : fugitive emissions up to a 10⁻⁶ mg*s⁻¹*m⁻¹ He maximum during 1500 cycles with any packing setup
- BH - CO₂ - SS0 - RT : fugitive emissions up to a 10⁻⁴ mg*s⁻¹*m⁻¹ He maximum during 1500 cycles with any packing setup
- BH - CO₂ - SS1 - RT : fugitive emissions up to a 10⁻⁴ mg*s⁻¹*m⁻¹ He maximum during 1500 cycles with one packing setup

The class AH-CO₂-SS0 is generally suitable for all kind of application also with dangerous, toxic or polluting liquids or gas and guarantee a high safety level.

The class BH-CO₂-SS0 is generally suitable polluting liquid or gases and can guarantee excellent performances also in case of infrequent maintenance.

The class BH-CO₂-SS1 is suitable for polluting liquids and can guarantee a low emission level.

All valves produced by RT are designed, produced and certified according to European Directive 93/23/EC (also known as Pressure Equipment Directive or PED). Since May 2001 RT have been qualified according to the PED requirement by the Notified Body TÜV SÜDDEUTSCHLAND according to module H (full quality assurance).

This qualification permit to use RT's valves for dangerous or not dangerous fluids (as specified in the directive 67/548/EC), without limitations for service pressure and temperature and falling in categories I, II or III of PED classification.

The pressure bearing parts are always made with materials specified in EN harmonized standards or qualified according to specific PMA procedures. These base materials are purchased by RT only from qualified factories according to Annex I art. 4 of 97/23/EC.



To meet the requirement of PED directive the valves are always supplied as CE marked with a tag plate indicating the service limits for the specific model based on body material, options and device installed.

With the delivered products are always supplied also:

- the declaration of conformity according to Annex VII of European Directive 97/23/EC
- the operating instructions according to Annex I point 3.4 of European Directive 97/23/EC and EN 764-6

On request RT can supply to his customers all details contained in the technical file for each single valve model including desing data, calculations and risk analysis.



On request RT can supply valves designed and produced to meet the requirement of European Directive 94/9/EC for equipment and protective system intended for use in explosive atmospheres, also known as Atex directive. The valves in this special configuration are designed to meet the requirement for equipment Category II Group 2 GD then to work controlling the risk of ignition in potentially explosive atmosphere. The valves in this group / category are certificated to not represent an ignition source under normal operation but also in case of expected malfunctioning in presence of gas or dust. According to Atex directive the valves meeting the requirement of Category II Group 2 GD can be used in the following zones:

- Zone 1 (an area in which an explosive atmosphere consisting of a mixture with air of dangerous substances in the form of gas, vapour or mist is likely to occur in normal operation occasionally)

- Zone 21 (an area in which an explosive atmosphere in the form of a cloud of combustible dust in air is likely to occur in normal operation occasionally)
- Zone 2 (an area in which an explosive atmosphere consisting of a mixture with air of dangerous substances in the form of gas, vapour or mist is not likely to occur in normal operation but, if it does occur, will persist for a short period only)
- Zone 22 (an area in which an explosive atmosphere in the form of a cloud of combustible dust in air is not likely to occur in normal operation but, if it does occur, will persist for a short period only)



The valves supplied in Atex version are provided with:

- Ex marking and tag plate with the equipment category and group classification (II 2 GD)
- Specific and additional installation maintenance and use instructions for use in potentially explosive atmospheres

On customer request RT can supply also the details of the file with design data, calculations and risk analysis. In case of additional device to be installed on the valve (electric actuators, pneumatic actuators, gearboxes, limit switches etc.) also these equipments will be provided in compatible Atex versions.



Gate Valves

APPLICATIONS

The gate valves are used where minimum pressure drop and / or bi-directional on-off service are required.

Typical applications are:

- water
- chemicals
- petrochemicals
- steam
- gases
- liquid gases (cryogenic service)

CONSTRUCTION DETAILS

Body

The body geometry is designed as the result of stress calculations to achieve the most regular distribution of the internal forces due to pressure action.

The body material is high quality cast steel. The seats surface is covered by a wear resistance stainless steel deposited by welding overlay with a hardness difference of +50 HB in comparison with the wedge seats. On request the seat surface can be covered also with stellite or other special material overlays.

Bonnet

The bonnet is the bolted type, or pressure seal type (for higher pressures), designed to achieve the minimum turbulence and flow resistance.

The bonnet material is the same of the body material. Beside, the bonnet is designed and manufactured in order to ensure a perfect seal, as well as to allow an easy reassembly and reassembly work.



Wedge

All RT's gate valves have a full bore and in the open position their wedge is fully retracted to ensure the lowest pressure drop. RT's gate valves can be provided with the following obturators:

- Split wedge (double disk wedge): this type is the best solution for small valves with frequent operation due to his durability guaranteed also by the construction with the inner parts in stainless steel. The normal wear is easily recovered by the automatic adjustment of two disk and a perfect tight can be obtained with low torque. In high and low temperature services, compensating the body deformations, this wedge provide the best performances. The split wedge is always required in case of valve installation with horizontal stem.
- Flexible wedge: this is the most used and well known type of wedge. Owing to his low weight and the flexibility due to his particular construction can be employed in medium and large size valves with very good result also in high



and low temperature services.

- Solid wedge: this type is generally used in larger size where due to small space between the two body seat other types can't be used (typically in short face to face valves). This execution is required also when the valves are used for fluid that can be solidified due to temperature variations.

Please refer to technical sheets for the execution provided by standard on each size and type.

Yoke and handwheel

The standard valves are provided with yoke sleeve and handwheel for manual operation. On request the yoke can be provided with a connection flange according to ISO 5210 that allow the mounting of other operation devices (actuator, gearbox, etc.). In high-pressure valves or in the larger sizes the yoke sleeve is supported by two thrust roll bearings. The yoke sleeve is treated to prevent the seizure and the corrosion. A feather key transmits the torque from the handwheel to the yoke sleeve and permits a quick and easy disassembling. The handwheel is retained by a clamping ring (seeger) and it is not rising.

Gate Valves

Stem

In all outside screw valves the stem is provided with integral backseat as emergency device in case of packing failure. The stem is produced with special turning machinery for a high resistance and durability. The stem thread is metric type according to ISO 2901 with trapezoidal section. The thread is left hand type in the way that the valve opens rotating clockwise the handwheel.

To avoid any leakage the stem has a high finish degree and a strict diametrical clearance.

Gasket

The standard gasket is in pure graphite stainless steel reinforced. This type of gasket is suitable for many different applications. For special applications (cryogenic gases, high corrosion acids etc.) RT can supply special gaskets designed for the specific application or according to customer specifications. All valves with round body are provided by standard with chambered gasket.

Packing

The standard packing is made of four or more pure graphite rings with square section. The first and the last ring are reinforced with stainless steel to avoid the extrusion.

Other materials like PTFE are available on request. The graphite is always treated with special corrosion inhibitors to prevent the corrosion of ferritic stainless steel stem due to galvanic cell action.

For special applications (cryogenic gases,

high corrosion acids, etc.) RT can supply special packings designed for the specific application or according to customer requirements.

To meet the TA-Luft requirements, on request, RT can supply valves with special design of stem and packing. The stuffing box housing is produced with a high finish degree and a strict clearance to guarantee a perfect tight of the packing.

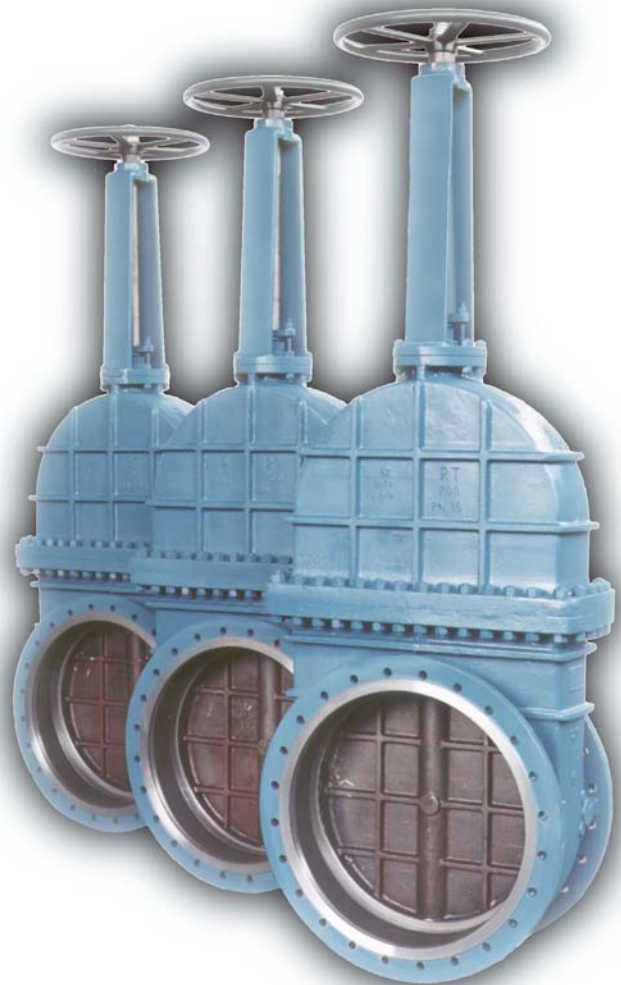



WARNINGS

- The gate valves are not designed for throttling and regulating service. A prolonged use in partially open position would generally cause some damages.
- The gate valves are not suitable for media which tend to produce high sedimentation or encrustation, as well as fluids containing foreign solids which, due to their hardness, present the risk to damage the seat faces.
- In case of horizontal installation the valves shall be always provided with split wedge and, for sizes over 200 mm, the yoke shall be sustained by appropriate devices.
- The solid wedge is always required for medium that can be subjected to solidification.
- In case of medium that, due to temperature gradient, can change his physical phase from liquid to gas or vapour, the gate valves shall be provided by appropriate safety device.

INSTALLATION

The standard installation position for the gate valves is with the vertical stem and upright (operator on the top). This position avoids many adverse influences and stresses during the functioning. Only the gate valves with split wedge can be installed also in horizontal position. The gate valves close turning the handwheel clockwise.

For a correct and easy installation please refer to the installation manual and follow the instructions there contained.



Gate Valve Inside Screw

PN 16 DN 50 - DN 800

Flanges PN 16 or PN 10



Fig. 205-505

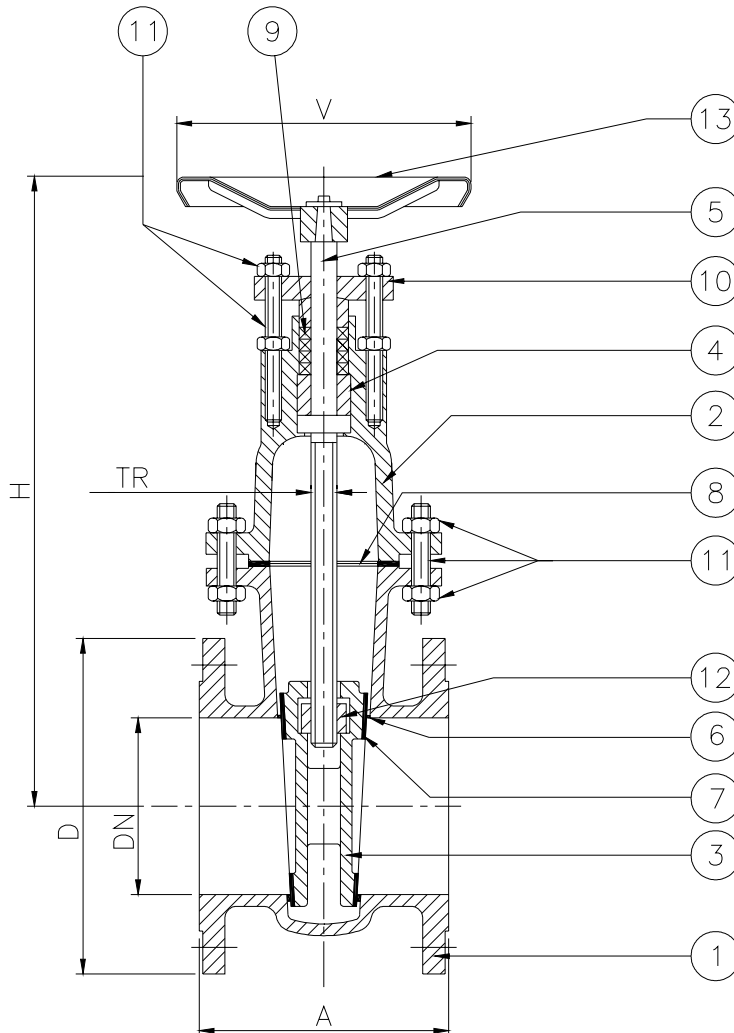

0948

Rel. 5.0

Standard features:

- Design EN 12516
EN 1984
- Face to face EN 558 series 14
DIN 3202 F4
- Flanges EN 1092-1/21/B1
- Materials EN 10213
EN 10269
EN 10088
- Bolts and nuts EN 1515-1
- Welding overlay AD-M HP 0
- Testing EN 1984
EN 12266
- Marking EN 19
- Certificates EN 10204

Optional versions:

- AD 2000 - A4
- TRD 110
- DIN 3230 Part 4
- DIN 3230 Part 5
- DIN 3230 Part 6
- TRbF 131
- TRbF 301 or 302
- ATEX
- TA-Luft
- With flanges PN 6
- With flanges form A, B2, C, D, E, F, G, H
- With butt welding ends (EN 12982 / EN 12627)
- With special devices (see pages 34 - 35)

	DESCRIPTION	FIG. 205	FIG. 305	FIG. 305-J	FIG. 405	Fig. 405-H	FIG. 505
1	Body	1.0619	1.4581	1.4308	1.7357	1.7379	1.1138
2	Bonnet	1.0619 (1)	1.4581	1.4308	1.7357	1.7379	1.1138
3	x Wedge	1.0619	1.4581	1.4308	1.7357	1.7379	1.1138
4	x Retaining ring	1.0511	1.4571	1.4301	1.0511	1.0511	1.0511
5	x Stem	1.4021 (2)	1.4571 (2)	1.4301 (2)	1.4021 (2)	1.4021 (2)	1.4021 (2)
6	Body seats	1.4502 (3)	1.4430 (3)	1.4316 (3)	1.4502 (3)	Stellite	1.4502 (3)
7	Wedge seats	1.4502 (3)	1.4581 (3)	1.4308 (3)	1.4502 (3)	Stellite	1.4502 (3)
8	O Gasket	Graphite+1.4401 (4)	Graphite+1.4401 (4)	PTFE (4)	Graphite+1.4401 (4)	Graphite+1.4401 (4)	Graphite+1.4401 (4)
9	O Packing	Graphite+1.4401 (4)	Graphite+1.4401 (4)	PTFE (4)	Graphite+1.4401 (4)	Graphite+1.4401 (4)	Graphite+1.4401 (4)
10	x Gland	1.0402	1.4571	1.4301	1.0402	1.0402	1.4301
11	Bolts	1.7225 (5)	1.4301 (5)	1.4301 (5)	1.7711 (5)	1.7711 (5)	1.7225 (5)
11	Nuts	1.1191 (5)	1.4301 (5)	1.4301 (5)	1.7225 (5)	1.7225 (5)	1.7225 (5)
12	x Sleeve	1.4401 NHT	1.4401 NHT	1.4301 NHT	1.4401 NHT	1.4401 NHT	1.4401 NHT
13	x Handwheel	Pressed steel	Pressed steel	Pressed steel	Pressed steel	Pressed steel	Pressed steel

(1) can be supplied 1.0352 from DN 50 up to DN 150.

(2) Also available on request 1,4571, 1.4301, 1.3964, Hastelloy, or other materials.

(3) Also available on request stellite, 1.4462 (duplex), 1.4430, 1.4316, Hastelloy, or other materials.

(4) Also available on request PTFE, Gore-tex, graphite, or other materials and different desing (e.g. cam-profile).

(5) Also available on request 1.7225 / 1.1191, 1.7711 / 1.7225, 1.4401, 1.4301, A4-70 or other materials.

O recommended spare parts for 2 years standard service; x recommended spare parts for 5 years standard service.

Dimensions

	DN	A	D	H	TR	V	Kg	$\Delta p^{(6)}$	Wedge ⁽⁷⁾
PN 16	50	150	165	280	18 x 4	200	15	16	Split
	65	170	185	340	20 x 4	200	22	16	Split
	80	180	200	370	20 x 4	200	25	16	Split
	100	190	220	380	20 x 4	200	30	16	Split
	125	200	250	420	24 x 5	250	37	16	Split
	150	210	285	500	24 x 5	250	50	16	Flexible
	200	230	340	600	28 x 5	300	80	16	Flexible
	250	250	405	760	32 x 6	400	148	16	Flexible
	300	270	460	825	32 x 6	400	175	13	Flexible
	350	290	520	910	32 x 6	400	245	10	Flexible
	400	310	580	950	36 x 6	400	295	7	Flexible
	450	330	640	1180	40 x 7	500	480	0	Flexible
	500	350	715	1215	40 x 7	500	605	0	Flexible
600	390	840	1380	40 x 7	500	930	0	Flexible	
700	430	910	1500	50 x 8	600	1070	0	Flexible	
800	470	1025	1670	50 x 8	600	1440	0	Flexible	
900	510	1125	1810	60 x 9	600	1770	0	Flexible	
1000	550	1255	2020	60 x 9	600	2120	0	Flexible	

(6) Maximum differential pressure for manoeuvre without gear box or by-pass according to EN 12570 (if equal to 0 the gearbox is recommended).

(7) Standard wedge type. Other execution available on request.

Pressure Temperature Ratings (°C / bar)

	PN	-195	-150	-100	-50	-10	0	20	100	150	200	250	300	350	400	425	450	475	500	525	550	575	600	
Fig. 205	16					16.0	16.0	15.8	14.9	13.7	12.4	11.4	10.3	9.6	9.2	7.6	5.9							
Fig. 305 ⁽⁸⁾	16			16.0	16.0	16.0	16.0	15.4	13.2	12.3	11.4	10.8	10.3	9.8	9.2	9.1	8.9	8.7	8.5	8.4	8.2			
Fig. 305-J	16	16.0	16.0	16.0	16.0	16.0	16.0	15.1	11.4	10.1	8.9	8.4	7.8											
Fig. 405 ⁽⁹⁾	16					16.0	16.0	16.0	16.0	16.0	16.0	16.0	16.0	15.3	14.2	13.9	13.5	10.9	8.3	6.1	3.9			
Fig. 405-H ⁽⁹⁾	16					16.0	16.0	16.0	16.0	16.0	16.0	16.0	16.0	16.0	16.0	15.8	15.5	12.6	9.7	7.2	4.7	3.3	2.0	
Fig. 505	16				16.0	16.0	16.0	15.6	14.2	13.5	12.8	12.4	12.1											

Please, in the inquiry and in the order, specify always the maximum service temperature when it's over 100 °C.

If the valves are provided with flanged connection PN 10 or PN 6 the maximum allowable pressure must be proportionally reduced.

(8) Suitable over 450 °C only if provided with stellite seats. (9) Suitable over 530 °C only if provided with 1.3964 stem.

Due to short face to face depending on DN and required execution some flange holes can be treaded.

General sale and delivery conditions and product guarantee as specified at pages 56 and 57.

Due to constant improvement all data and details contained in this catalogue are purely indicative and they can be subjected to change without notice.

Gate Valve Outside Screw



PN 16 DN 50 - DN 800

Flanges PN 16 or PN 10

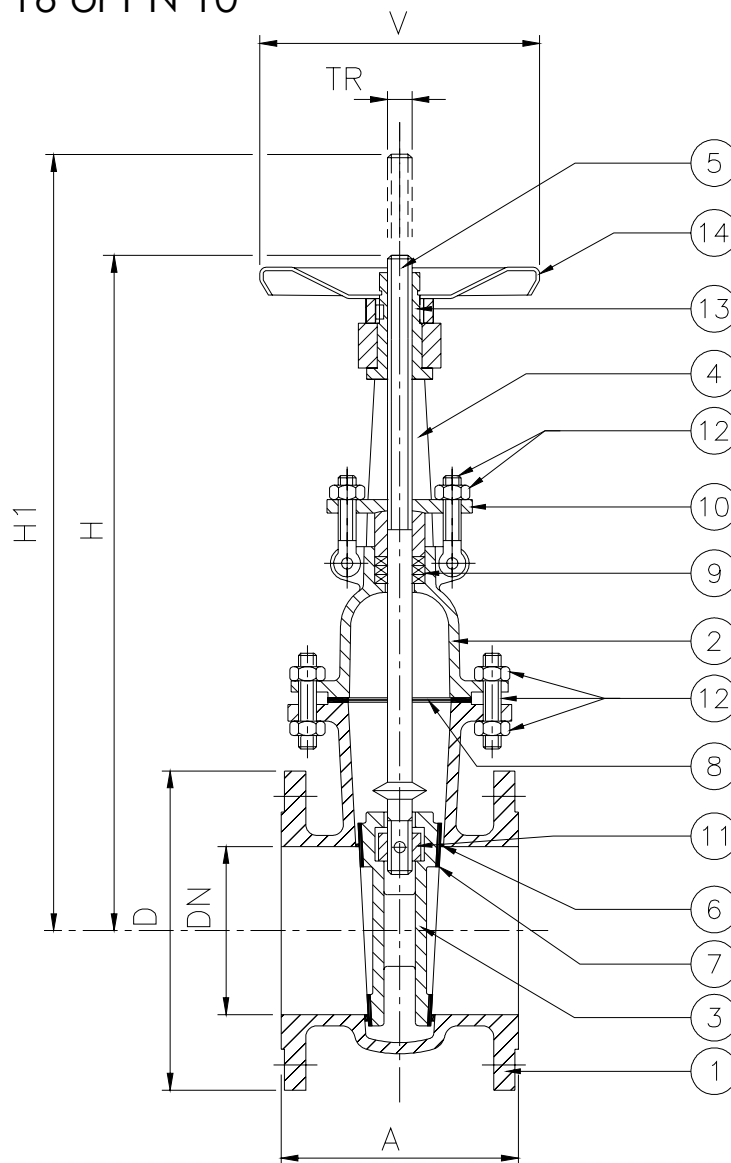

Fig. 210-510



0948

Rel. 5.0

Standard features:

- Design EN 12516
EN 1984
- Face to face EN 558 series 14
DIN 3202 F4
- Flanges EN 1092-1/21/B1
- Materials EN 10213
EN 10269
EN 10088
- Bolts and nuts EN 1515-1
- Welding overlay AD-M HP 0
- Testing EN 1984
EN 12266
- Marking EN 19
- Certificates EN 10204

Optional versions:

- AD 2000 – A4
- TRD 110
- DIN 3230 Part 4
- DIN 3230 Part 5
- DIN 3230 Part 6
- TRbF 131
- TRbF 301 or 302
- ATEX
- TA-Luft
- With flanges PN 6
- With flanges form A, B2, C, D, E, F, G, H
- With butt welding ends (EN 12982 / EN 12627)
- With special devices (see pages 34 – 35)

	DESCRIPTION	FIG. 210	FIG. 310	FIG. 310-J	FIG. 410	Fig. 410-H	FIG. 510
1	Body	1.0619	1.4581	1.4308	1.7357	1.7379	1.1138
2	Bonnet	1.0619	1.4581	1.4308	1.7357	1.7379	1.1138
3	x Wedge	1.0619	1.4581	1.4308	1.7357	1.7379	1.1138
4	Yoke	1.0619	1.4581	1.4308	1.7357	1.7379	1.1138
5	x Stem	1.4021 ⁽¹⁾	1.4571 ⁽¹⁾	1.4301 ⁽¹⁾	1.4021 ⁽¹⁾	1.4021 ⁽¹⁾	1.4021 ⁽¹⁾
6	Body seats	1.4502 ⁽²⁾	1.4430 ⁽²⁾	1.4316 ⁽²⁾	1.4502 ⁽²⁾	Stellite	1.4502 ⁽²⁾
7	Wedge seats	1.4502 ⁽²⁾	1.4581 ⁽²⁾	1.4308 ⁽²⁾	1.4502 ⁽²⁾	Stellite	1.4502 ⁽²⁾
8	O Gasket	Graphite+1.4401 ⁽³⁾	Graphite+1.4401 ⁽³⁾	PTFE ⁽³⁾	Graphite+1.4401 ⁽³⁾	Graphite+1.4401 ⁽³⁾	Graphite+1.4401 ⁽³⁾
9	O Packing	Graphite+1.4401 ⁽³⁾	Graphite+1.4401 ⁽³⁾	PTFE ⁽³⁾	Graphite+1.4401 ⁽³⁾	Graphite+1.4401 ⁽³⁾	Graphite+1.4401 ⁽³⁾
10	x Gland	1.0402	1.4571	1.4301	1.0402	1.0402	1.4301
11	x Boss	1.4571	1.4571	1.4301	1.4571	1.4571	1.4571
12	Bolts	1.7225 ⁽⁴⁾	1.4301 ⁽⁴⁾	1.4301 ⁽⁴⁾	1.7711 ⁽⁴⁾	1.7711 ⁽⁴⁾	1.7225 ⁽⁴⁾
12	Nuts	1.1191 ⁽⁴⁾	1.4301 ⁽⁴⁾	1.4301 ⁽⁴⁾	1.7225 ⁽⁴⁾	1.7225 ⁽⁴⁾	1.7225 ⁽⁴⁾
13	x Yoke sleeve	1.0511 NHT	1.0511 NHT	1.0511 NHT	1.0511 NHT	1.0511 NHT	1.0511 NHT
14	x Handwheel	Pressed steel	Pressed steel	Pressed steel	Pressed steel	Pressed steel	Pressed steel

⁽¹⁾ Also available on request 1.4571, 1.4301, 1.3964, Hastelloy, or other materials.

⁽²⁾ Also available on request stellite, 1.4462 (duplex), 1.4430, 1.4316, Hastelloy, or other materials.

⁽³⁾ Also available on request PTFE, Gore-tex, graphite, or other materials and different desing (e.g. cam-profile).

⁽⁴⁾ Also available on request 1.7225 / 1.1191, 1.7711 / 1.7225, 1.4401, 1.4301, A4-70 or other materials.

O recommended spare parts for 2 years standard service; x recommended spare parts for 5 years standard service.

Dimensions

	DN	A	D	H	H1	TR	V	Kg	$\Delta p^{(5)}$	Wedge ⁽⁶⁾
PN 16	50	150	165	315	375	18 x 4	200	15	16	Split
	65	170	185	370	450	20 x 4	200	25	16	Split
	80	180	200	410	500	20 x 4	200	27	16	Split
	100	190	220	450	560	22 x 5	200	35	16	Split
	125	200	250	525	660	24 x 5	250	40	16	Split
	150	210	285	600	765	24 x 5	250	55	16	Flexible
	200	230	340	760	975	28 x 5	300	82	16	Flexible
	250	250	405	990	1255	32 x 6	400	155	16	Flexible
	300	270	460	1095	1415	32 x 6	400	225	13	Flexible
	350	290	520	1245	1610	32 x 6	400	265	10	Flexible
	400	310	580	1350	1770	36 x 6	500	320	8	Flexible
	450	330	640	1180	2100	40 x 7	500	490	8	Flexible
	500	350	715	1660	2180	40 x 7	500	630	8	Flexible
	600	390	840	1965	2585	40 x 7	500	990	6	Flexible
700	430	910	2185	2905	50 x 8	600	1150	1	Flexible	
800	470	1025	2500	3320	50 x 8	600	1550	0	Flexible	
900	510	1125	2820	3720	60 x 9	600	1800	0	Flexible	
1000	550	1255	3150	4150	60 x 9	600	2160	0	Flexible	

⁽⁵⁾ Maximum differential pressure for manoeuvre without gear box or by-pass according to EN 12570 (if equal to 0 the gearbox is recommended).

⁽⁶⁾ Standard wedge type. Other execution available on request.

Pressure Temperature Ratings (°C / bar)

	PN	-195	-150	-100	-50	-10	0	20	100	150	200	250	300	350	400	425	450	475	500	525	550	575	600	
Fig. 210	16				16.0	16.0	15.8	14.9	13.7	12.4	11.4	10.3	9.6	9.2	7.6	5.9								
Fig. 310 ⁽⁸⁾	16		16.0	16.0	16.0	16.0	15.4	13.2	12.3	11.4	10.8	10.3	9.8	9.2	9.1	8.9	8.7	8.5	8.4	8.2				
Fig. 310-J	16	16.0	16.0	16.0	16.0	16.0	15.1	11.4	10.1	8.9	8.4	7.8												
Fig. 410 ⁽⁸⁾ ⁽⁹⁾	16				16.0	16.0	16.0	16.0	16.0	16.0	16.0	16.0	15.3	14.2	13.9	13.5	10.9	8.3	6.1	3.9				
Fig. 410-H ⁽⁹⁾	16				16.0	16.0	16.0	16.0	16.0	16.0	16.0	16.0	16.0	16.0	15.8	15.5	12.6	9.7	7.2	4.7	3.3	2.0		
Fig. 510	16		16.0	16.0	16.0	15.6	14.2	13.5	12.8	12.4	12.1													

Please, in the inquiry and in the order, specify always the maximum service temperature when it's over 100 °C.

If the valves are provided with flanged connection PN 10 or PN 6 the maximum allowable pressure must be proportionally reduced.

⁽⁷⁾ Suitable over 450 °C only if provided with stellite seats. ⁽⁸⁾ Suitable over 530 °C only if provided with 1.3964 stem.

Due to short face to face depending on DN and required execution some flange holes can be treaded.

General sale and delivery conditions and product guarantee as specified at pages 56 and 57.

Due to constant improvement all data and details contained in this catalogue are purely indicative and they can be subjected to change without notice.

Gate Valve Inside Screw

PN 40 DN 50 - DN 150

PN 25 DN 200 - DN 800

Flanges PN 40 or PN 25 or PN 16



Fig. 235-535

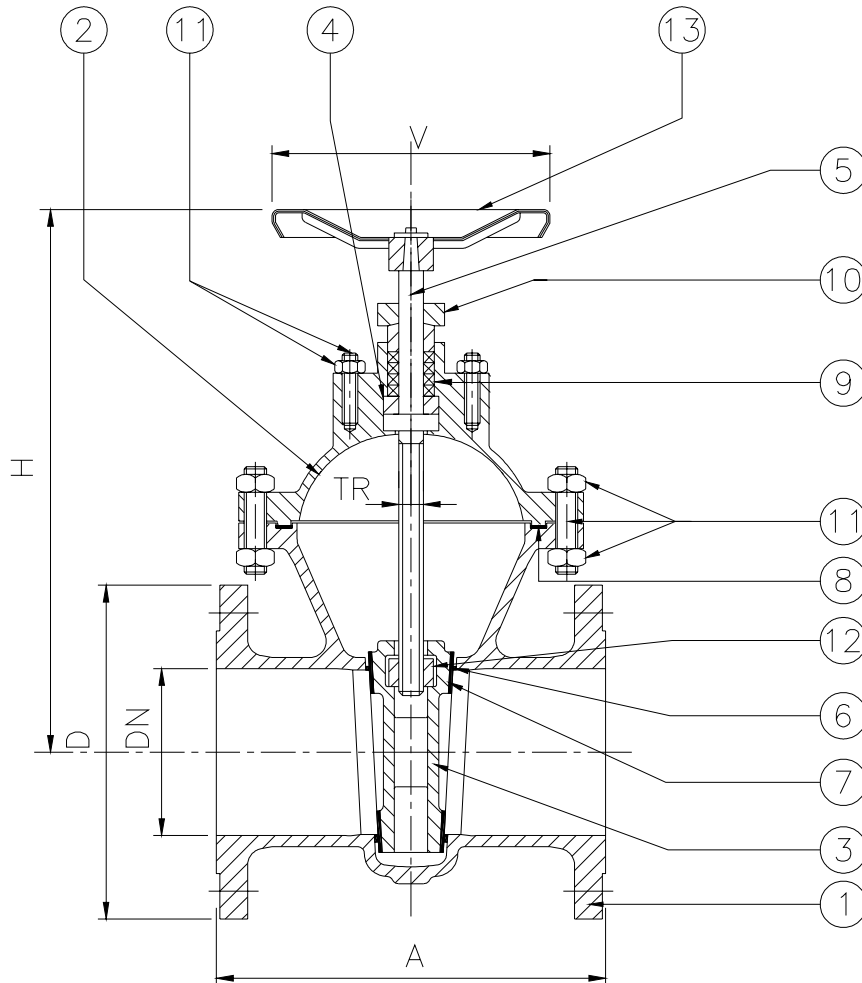

0948

Rel. 5.0

Standard features:

- Design EN 12516
 EN 1984
- Face to face EN 558 series 15
 DIN 3202 F5
- Flanges EN 1092-1/21/B1
- Materials EN 10213
 EN 10269
 EN 10088
- Bolts and nuts EN 1515-1
- Welding overlay AD-M HP 0
- Testing EN 1984
 EN 12266
- Marking EN 19
- Certificates EN 10204

Optional versions:

- AD 2000 – A4
- TRD 110
- DIN 3230 Part 4
- DIN 3230 Part 5
- DIN 3230 Part 6
- TRbF 131
- TRbF 301 or 302
- ATEX
- TA-Luft
- With flanges PN 10 or PN 6
- With flanges form A, B2, C, D, E, F, G, H
- With butt welding ends (EN 12982 / EN 12627)
- With special devices (see pages 34 – 35)

	DESCRIPTION	FIG. 235	FIG. 335	FIG. 335-J	FIG. 435	Fig. 435-H	FIG. 535
1	Body	1.0619	1.4581	1.4308	1.7357	1.7379	1.1138
2	Bonnet	1.0619	1.4581	1.4308	1.7357	1.7379	1.1138
3	x Wedge	1.0619	1.4581	1.4308	1.7357	1.7379	1.1138
4	x Retaining ring	1.0511	1.4571	1.4301	1.0511	1.0511	1.0511
5	x Stem	1.4021 (1)	1.4571 (1)	1.4301 (1)	1.4021 (1)	1.4021 (1)	1.4021 (1)
6	Body seats	1.4502 (2)	1.4430 (2)	1.4316 (2)	1.4502 (2)	Stellite	1.4502 (2)
7	Wedge seats	1.4502 (2)	1.4581 (2)	1.4308 (2)	1.4502 (2)	Stellite	1.4502 (2)
8	O Gasket	Graphite + SS (3)	Graphite + SS (3)	PTFE (3)	Graphite + SS (3)	Graphite + SS (3)	Graphite + SS (3)
9	O Packing	Graphite + SS (3)	Graphite + SS (3)	PTFE (3)	Graphite + SS (3)	Graphite + SS (3)	Graphite + SS (3)
10	x Gland	1.0402	1.4571	1.4301	1.0402	1.0402	1.4301
11	Bolts	1.7225 (4)	1.4301 (4)	1.4301 (4)	1.7711 (4)	1.7711 (4)	1.7225 (4)
11	Nuts	1.1191 (4)	1.4301 (4)	1.4301 (4)	1.7225 (4)	1.7225 (4)	1.7225 (4)
12	x Sleeve	1.4401 NHT	1.4401 NHT	1.4301 NHT	1.4401 NHT	1.4401 NHT	1.4401 NHT
13	x Handwheel	Pressed steel	Pressed steel	Pressed steel	Pressed steel	Pressed steel	Pressed steel

(1) Also available on request 1.4571, 1.4301, 1.3964, Hastelloy, or other materials.

(2) Also available on request stellite, 1.4462 (duplex), 1.4430, 1.4316, Hastelloy, or other materials.

(3) Also available on request PTFE, Gore-tex, graphite, or other materials and different desing (e.g. cam-profile).

(4) Also available on request 1.7225 / 1.1191, 1.7711 / 1.7225, 1.4401, 1.4301, A4-70 or other materials.

O recommended spare parts for 2 years standard service; x recommended spare parts for 5 years standard service.

Dimensions

	DN	A	D	H	TR	V	Kg	$\Delta p^{(5)}$	Wedge (6)
PN 40	50	250	165	275	18 x 4	200	20	40	Split
	65	270	185	320	20 x 4	200	30	40	Split
	80	280	200	330	20 x 4	200	35	40	Split
	100	300	235	365	20 x 4	200	50	40	Split
	125	325	270	480	25 x 5	250	65	40	Split
PN 25	150	350	300	500	25 x 5	250	95	40	Flexible
	200	400	360	570	28 x 5	300	145	16	Flexible
	250	450	425	700	32 x 6	400	215	16	Flexible
	300	500	485	765	36 x 6	400	315	14	Flexible
	350	550	555	915	36 x 6	500	385	12	Flexible
	400	600	620	1030	40 x 7	500	570	0	Flexible
	450	650	670	1140	40 x 7	500	755	0	Flexible
	500	700	730	1240	50 x 8	600	815	0	Flexible
	600	800	845	1440	50 x 8	600	1070	0	Flexible
	700	900	960	1540	60 x 9	600	1925	0	Solid
800	1000	1085	1710	70 x 10	600	2270	0	Solid	

(5) Maximum differential pressure for manoeuvre without gear box or by-pass according to EN 12570 (if equal to 0 the gearbox is recommended).

(6) Standard wedge type. Other execution available on request.

Pressure Temperature Ratings (°C / bar)

	PN	-195	-150	-100	-50	-10	0	20	100	150	200	250	300	350	400	425	450	475	500	525	550	575	600	
Fig. 235	25				25.0	25.0	24.7	23.3	21.4	19.4	17.8	16.1	15.0	14.4	11.8	9.2								
Fig. 335(7)	25			25.0	25.0	25.0	24.1	20.6	19.2	17.8	16.9	16.1	15.3	14.4	14.2	13.9	13.6	13.3	13.1	12.8				
Fig. 335-J	25	25.0	25.0	25.0	25.0	25.0	23.6	17.8	15.8	13.9	13.1	12.2												
Fig. 435(7)(8)	25				25.0	25.0	25.0	25.0	25.0	25.0	25.0	25.0	23.9	22.2	21.7	21.1	17.1	13.0	9.6	6.1				
Fig. 435-H(8)	25				25.0	25.0	25.0	25.0	25.0	25.0	25.0	25.0	25.0	25.0	24.6	24.2	19.7	15.1	11.2	7.3	5.2	3.1		
Fig. 535	25			25.0	25.0	25.0	24.4	22.2	21.1	20.0	19.4	18.9												
Fig. 235	40				40.0	40.0	39.5	37.3	34.2	31.1	28.4	25.8	24.0	23.1	18.9	14.8								
Fig. 335(7)	40			40.0	40.0	40.0	38.6	32.9	30.7	28.4	27.1	25.8	24.4	23.1	22.7	22.2	21.8	21.3	20.9	20.4				
Fig. 335-J	40	40.0	40.0	40.0	40.0	40.0	37.7	28.4	25.3	22.2	20.9	19.6												
Fig. 435(7)(8)	40				40.0	40.0	40.0	40.0	40.0	40.0	40.0	40.0	38.2	35.6	34.7	33.8	27.3	20.8	15.3	9.8				
Fig. 435-H(8)	40				40.0	40.0	40.0	40.0	40.0	40.0	40.0	40.0	40.0	40.0	39.4	38.8	31.5	24.2	18.0	11.7	8.4	5.0		
Fig. 535	40			40.0	40.0	40.0	39.1	35.6	33.8	32.0	31.1	30.2												

Please, in the inquiry and in the order, specify always the maximum service temperature when it's over 100 °C.

If the valves are provided with flanged connection PN 16 or PN 10 the maximum allowable pressure should be proportionally reduced.

(7) Suitable over 450 °C only if provided with stellite seats. (8) Suitable over 530 °C only if provided with 1.3964 stem.

General sale and delivery conditions and product guarantee as specified at pages 56 and 57.

Due to constant improvement all data and details contained in this catalogue are purely indicative and they can be subjected to change without notice.

Gate Valve Outside Screw



PN 40 DN 50 - DN 150

PN 25 DN 200 - DN 800

Flanges PN 40 or PN 25 or PN 16

Fig. 240-540

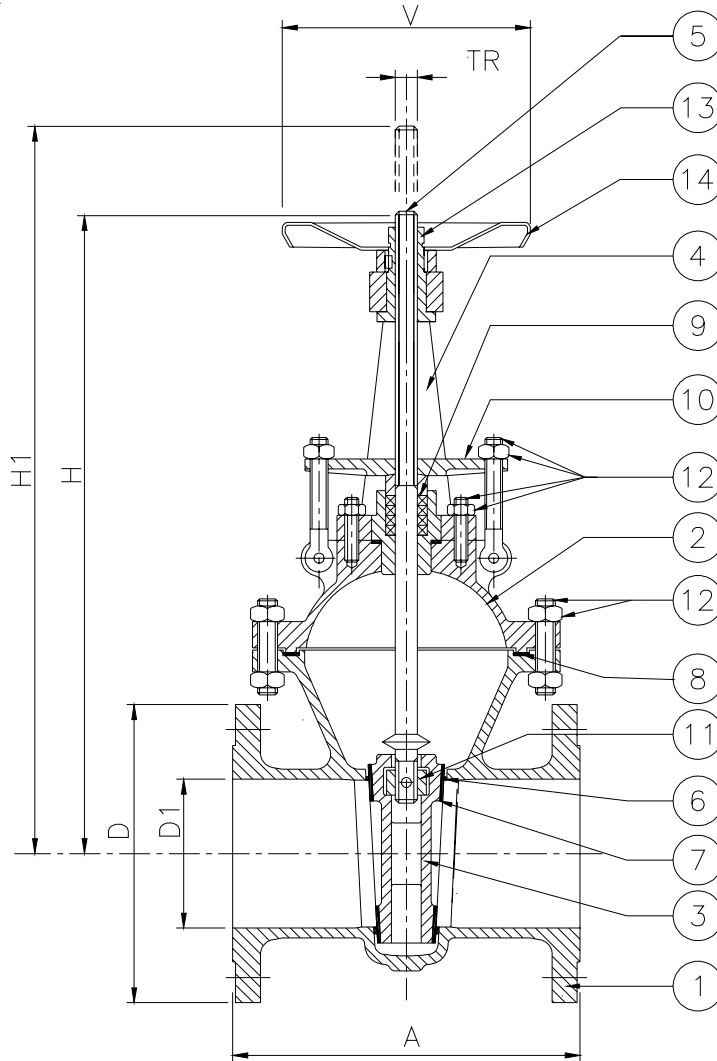

0948

Rel. 5.0

Standard features:

- Design EN 12516
 EN 1984
- Face to face EN 558 series 15
 DIN 3202 F5
- Flanges EN 1092-1/21/B1
- Materials EN 10213
 EN 10269
 EN 10088
- Bolts and nuts EN 1515-1
- Welding overlay AD-M HP 0
- Testing EN 1984
 EN 12266
- Marking EN 19
- Certificates EN 10204

Optional versions:

- AD 2000 – A4
- TRD 110
- DIN 3230 Part 4
- DIN 3230 Part 5
- DIN 3230 Part 6
- TRbF 131
- TRbF 301 or 302
- ATEX
- TA-Luft
- With flanges PN 10 or PN 16
- With flanges form A, B2, C, D, E, F, G, H
- With butt welding ends (EN 12982 / EN 12627)
- With special devices (see pages 34 – 35)

	DESCRIPTION	FIG. 240	FIG. 340	FIG. 340-J	FIG. 440	FIG. 440-H	FIG. 540
1	Body	1.0619	1.4581	1.4308	1.7357	1.7379	1.1138
2	Bonnet	1.0619	1.4581	1.4308	1.7357	1.7379	1.1138
3	x Wedge	1.0619	1.4581	1.4308	1.7357	1.7379	1.1138
4	Yoke	1.0619	1.4581	1.4308	1.7357	1.7379	1.1138
5	x Stem	1.4021 (1)	1.4571 (1)	1.4301 (1)	1.4021 (1)	1.4021 (1)	1.4021 (1)
6	Body seats	1.4502 (2)	1.4430 (2)	1.4316 (2)	1.4502 (2)	Stellite	1.4502 (2)
7	Wedge seats	1.4502 (2)	1.4581 (2)	1.4308 (2)	1.4502 (2)	Stellite	1.4502 (2)
8	O Gasket	Graphite + SS (3)	Graphite + SS (3)	PTFE (3)	Graphite + SS (3)	Graphite + SS (3)	Graphite + SS (3)
9	O Packing	Graphite + SS (3)	Graphite + SS (3)	PTFE (3)	Graphite + SS (3)	Graphite + SS (3)	Graphite + SS (3)
10	x Gland	1.0402	1.4571	1.4301	1.0402	1.0402	1.4301
11	x Boss	1.4571	1.4571	1.4301	1.4571	1.4571	1.4571
12	Bolts	1.7225 (4)	1.4301 (4)	1.4301 (4)	1.7711 (4)	1.7711 (4)	1.7225 (4)
12	Nuts	1.1191 (4)	1.4301 (4)	1.4301 (4)	1.7225 (4)	1.7225 (4)	1.7225 (4)
13	x Yoke sleeve	1.0511 NHT	1.0511 NHT	1.0511 NHT	1.0511 NHT	1.0511 NHT	1.0511 NHT
14	x Handwheel	Pressed steel	Pressed steel	Pressed steel	Pressed steel	Pressed steel	Pressed steel

(1) Also available on request 1.4571, 1.4301, 1.3964, Hastelloy, or other materials.

(2) Also available on request stellite, 1.4462 (duplex), 1.4430, 1.4316, Hastelloy, or other materials.

(3) Also available on request PTFE, Gore-tex, graphite, or other materials and different desing (e.g. cam-profile).

(4) Also available on request 1.7225 / 1.1191, 1.7711 / 1.7225, 1.4401, 1.4301, A4-70 or other materials.

O recommended spare parts for 2 years standard service; x recommended spare parts for 5 years standard service.

Dimensions

	DN	A	D	H	H1	TR	V	Kg	$\Delta p^{(5)}$	Wedge (6)
PN 40	50	250	165	340	400	18 x 4	200	23	40	Split
	65	270	185	360	435	20 x 4	200	31	40	Split
	80	280	200	410	500	20 x 4	200	36	40	Split
	100	300	235	500	610	22 x 5	250	53	40	Split
	125	325	270	535	670	24 x 5	250	73	40	Split
PN 25	150	350	300	615	780	24 x 5	250	98	40	Flexible
	200	400	360	720	935	28 x 5	300	150	22	Flexible
	250	450	425	975	1240	32 x 6	400	230	19	Flexible
	300	500	485	1045	1360	36 x 6	500	330	17	Flexible
	350	550	555	1250	1615	36 x 6	500	400	12	Flexible
	400	600	620	1410	1830	40 x 7	500	600	12	Flexible
	450	650	670	1640	2110	50 x 8	600	790	12	Flexible
	500	700	730	1645	2165	50 x 8	600	845	12	Flexible
	600	800	845	1980	2600	50 x 8	600	1125	7	Flexible
	700	900	960	2190	3010	60 x 9	600	2000	1	Flexible
	800	1000	1085	2800	3630	70 x 10	600	2270	0	Flexible

(5) Maximum differential pressure for manoeuvre without gear box or by-pass according to EN 12570 (if equal to 0 the gearbox is recommended).

(6) Standard wedge type. Other execution available on request.

Pressure Temperature Ratings (°C / bar)

	PN	-195	-150	-100	-50	-10	0	20	100	150	200	250	300	350	400	425	450	475	500	525	550	575	600	
Fig. 240	25				25.0	25.0	24.7	23.3	21.4	19.4	17.8	16.1	15.0	14.4	11.8	9.2								
Fig. 340(7)	25			25.0	25.0	25.0	24.1	20.6	19.2	17.8	16.9	16.1	15.3	14.4	14.2	13.9	13.6	13.3	13.1	12.8				
Fig. 340-J	25	25.0	25.0	25.0	25.0	25.0	23.6	17.8	15.8	13.9	13.1	12.2												
Fig. 440(7)(8)	25				25.0	25.0	25.0	25.0	25.0	25.0	25.0	25.0	23.9	22.2	21.7	21.1	17.1	13.0	9.6	6.1				
Fig. 440-H(8)	25				25.0	25.0	25.0	25.0	25.0	25.0	25.0	25.0	25.0	25.0	24.6	24.2	19.7	15.1	11.2	7.3	5.2	3.1		
Fig. 540	25				25.0	25.0	25.0	24.4	22.2	21.1	20.0	19.4	18.9											
Fig. 240	40				40.0	40.0	39.5	37.3	34.2	31.1	28.4	25.8	24.0	23.1	18.9	14.8								
Fig. 340(7)	40			40.0	40.0	40.0	38.6	32.9	30.7	28.4	27.1	25.8	24.4	23.1	22.7	22.2	21.8	21.3	20.9	20.4				
Fig. 340-J	40	40.0	40.0	40.0	40.0	40.0	37.7	28.4	25.3	22.2	20.9	19.6												
Fig. 440(7)(8)	40				40.0	40.0	40.0	40.0	40.0	40.0	40.0	40.0	40.0	38.2	35.6	34.7	33.8	27.3	20.8	15.3	9.8			
Fig. 440-H(8)	40				40.0	40.0	40.0	40.0	40.0	40.0	40.0	40.0	40.0	40.0	39.4	38.8	31.5	24.2	18.0	11.7	8.4	5.0		
Fig. 540	40				40.0	40.0	40.0	39.1	35.6	33.8	32.0	31.1	30.2											

Please, in the inquiry and in the order, specify always the maximum service temperature when it's over 100 °C.

If the valves are provided with flanged connection PN 16 or PN 10 the maximum allowable pressure should be proportionally reduced.

(7) Suitable over 450 °C only if provided with stellite seats. (8) Suitable over 530 °C only if provided with 1.3964 stem.

General sale and delivery conditions and product guarantee as specified at pages 56 and 57.

Due to constant improvement all data and details contained in this catalogue are purely indicative and they can be subjected to change without notice.

Gate Valve Outside Screw



PN 63 DN 50 - DN 400

Flanges PN 63 or PN 40

Fig. 250-550

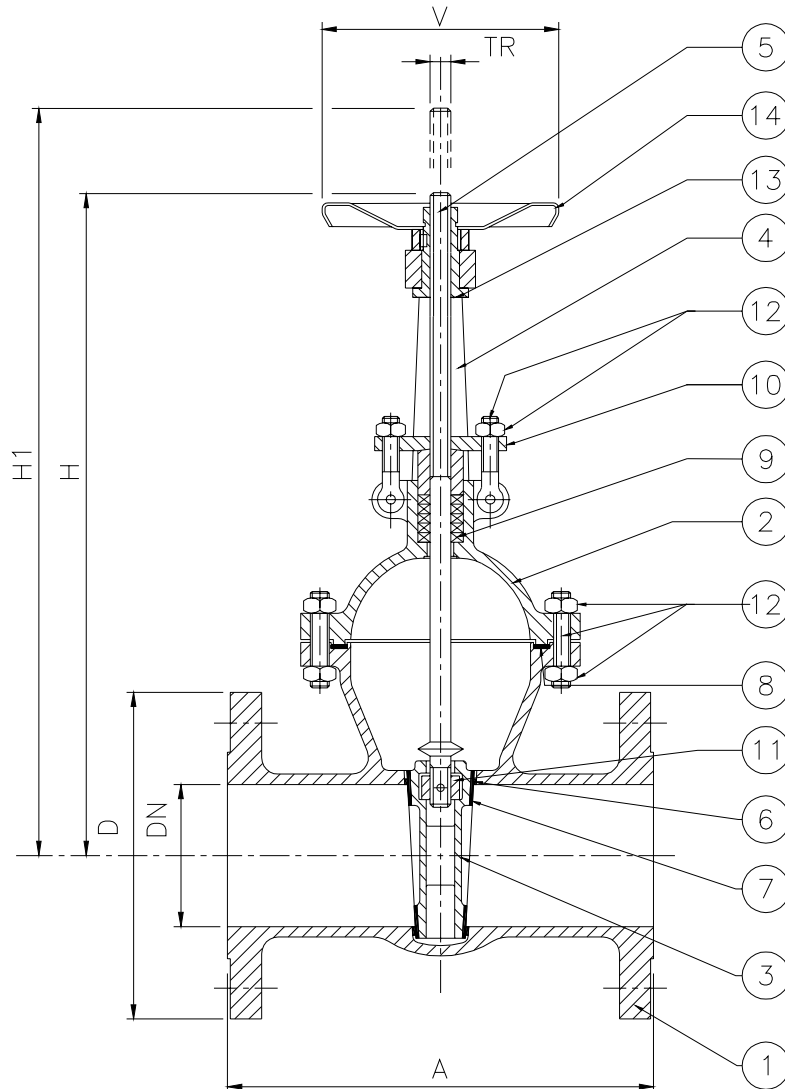

0948

Rel. 5.0

Standard features:

- Design EN 12516
EN 1984
- Face to face EN 558 series 26
DIN 3202 F7
- Flanges EN 1092-1/21/B2
- Materials EN 10213
EN 10269
EN 10088
- Bolts and nuts EN 1515-1
- Welding overlay AD-M HP 0
- Testing EN 1984
EN 12266
- Marking EN 19
- Certificates EN 10204

Optional versions:

- AD 2000 – A4
- TRD 110
- DIN 3230 Part 4
- DIN 3230 Part 5
- DIN 3230 Part 6
- TRbF 131
- TRbF 301 or 302
- ATEX
- TA-Luft
- With flanges PN 25 or PN 16
- With flanges form A, B2, C, D, E, F, G, H
- With butt welding ends (EN 12982 / EN 12627)
- With special devices (see pages 34 – 35)

	DESCRIPTION	FIG. 250	FIG. 350	FIG. 350-J	FIG. 450	FIG. 450-H	FIG. 550
1	Body	1.0619	1.4581	1.4308	1.7357	1.7379	1.1138
2	Bonnet	1.0619	1.4581	1.4308	1.7357	1.7379	1.1138
3	x Wedge	1.0619	1.4581	1.4308	1.7357	1.7379	1.1138
4	Yoke	1.0619	1.4581	1.4308	1.7357	1.7379	1.1138
5	x Stem	1.4021 (1)	1.4571 (1)	1.4301 (1)	1.4021 (1)	1.4021 (1)	1.4021 (1)
6	Body seats	1.4502 (2)	1.4430 (2)	1.4316 (2)	1.4502 (2)	Stellite	1.4502 (2)
7	Wedge seats	1.4502 (2)	1.4581 (2)	1.4308 (2)	1.4502 (2)	Stellite	1.4502 (2)
8	O Gasket	Graphite + SS (3)	Graphite + SS (3)	PTFE (3)	Graphite + SS (3)	Graphite + SS (3)	Graphite + SS (3)
9	O Packing	Graphite + SS (3)	Graphite + SS (3)	PTFE (3)	Graphite + SS (3)	Graphite + SS (3)	Graphite + SS (3)
10	x Gland	1.0402	1.4571	1.4301	1.0402	1.0402	1.4301
11	x Boss	1.4571	1.4571	1.4301	1.4571	1.4571	1.4571
12	Bolts	1.7225 (4)	1.4301 (4)	1.4301 (4)	1.7711 (4)	1.7711 (4)	1.7225 (4)
12	Nuts	1.1191 (4)	1.4301 (4)	1.4301 (4)	1.7225 (4)	1.7225 (4)	1.7225 (4)
13	x Yoke sleeve	1.0511 NHT	1.0511 NHT	1.0511 NHT	1.0511 NHT	1.0511 NHT	1.0511 NHT
14	x Handwheel	Pressed steel	Pressed steel	Pressed steel	Pressed steel	Pressed steel	Pressed steel

(1) Also available on request 1.4571, 1.4301, 1.3964, Hastelloy, or other materials.

(2) Also available on request stellite, 1.4462 (duplex), 1.4430, 1.4316, Hastelloy, or other materials.

(3) Also available on request PTFE, Gore-tex, graphite, or other materials and different desing (e.g. cam-profile).

(4) Also available on request 1.7225 / 1.1191, 1.7711 / 1.7225, 1.4401, 1.4301, A4-70 or other materials.

O recommended spare parts for 2 years standard service; x recommended spare parts for 5 years standard service.

Dimensions

	DN	A	D	H	H1	TR	V	Kg	Δp ⁽⁵⁾	Wedge ⁽⁶⁾
PN 63	50	250	180	380	440	20 x 4	200	35	63	Split
	65	290	205	455	530	22 x 5	200	44	63	Split
	80	310	215	465	545	22 x 5	250	48	63	Split
	100	350	250	490	600	22 x 5	250	57	63	Split
	125	400	295	615	750	24 x 5	250	81	63	Split
	150	450	345	695	860	28 x 5	300	125	63	Flexible
	200	550	415	845	1060	28 x 5	300	210	51	Flexible
	250	650	470	1000	1265	36 x 6	500	400	51	Flexible
	300	750	530	1140	1455	36 x 6	500	540	39	Flexible
	350	850	600	1250	1650	40 x 7	500	850	23	Flexible
	400	950	670	1430	1850	50 x 8	600	1120	15	Flexible
	450	1050	700	1490	1910	60 x 9	600	1630	4	Flexible
500	1150	800	1830	2350	70 x 10	600	1830	0	Flexible	

(5) Maximum differential pressure for manoeuvre without gear box or by-pass according to EN 12570 (if equal to 0 the gearbox is mandatory).

(6) Standard wedge type. Other execution available on request.

Pressure Temperature Ratings (°C / bar)

	PN	-195	-150	-100	-50	-10	0	20	100	150	200	250	300	350	400	425	450	475	500	525	550	575	600
Fig. 250	63				63,0	63,0	62,2	58,8	53,9	49,0	44,8	40,6	37,8	36,4	29,8	23,2							
Fig. 350(7)	63			63,0	63,0	63,0	63,0	60,8	51,8	48,3	44,8	42,7	40,6	38,5	36,4	35,7	35,0	34,3	33,6	32,9	32,2		
Fig. 350-J	63	63,0	63,0	63,0	63,0	63,0	59,4	44,8	39,9	35,0	32,9	30,8											
Fig. 450(7)(8)	63				63,0	63,0	63,0	63,0	63,0	63,0	63,0	63,0	63,0	60,2	56,0	54,6	53,2	43,0	32,8	24,1	15,4		
Fig. 450-H(8)	63				63,0	63,0	63,0	63,0	63,0	63,0	63,0	63,0	63,0	63,0	63,0	62,0	61,0	49,6	38,1	28,3	18,5	13,2	7,8
Fig. 550	63				63,0	63,0	63,0	61,6	56,0	53,2	50,4	49,0	47,6										

Please, in the inquiry and in the order, specify always the maximum service temperature when it's over 100 °C.

If the valves are provided with flanged connection PN 40 the maximum allowable pressure should be proportionally reduced.

(7) Suitable over 450 °C only if provided with stellite seats. (8) Suitable over 530 °C only if provided with 1.3964 stem.

General sale and delivery conditions and product guarantee as specified at pages 56 and 57.

Due to constant improvement all data and details contained in this catalogue are purely indicative and they can be subjected to change without notice.

Gate Valve Outside Screw



PN 100 DN 50 - DN 300

Flanges PN 100

Fig. 260-560

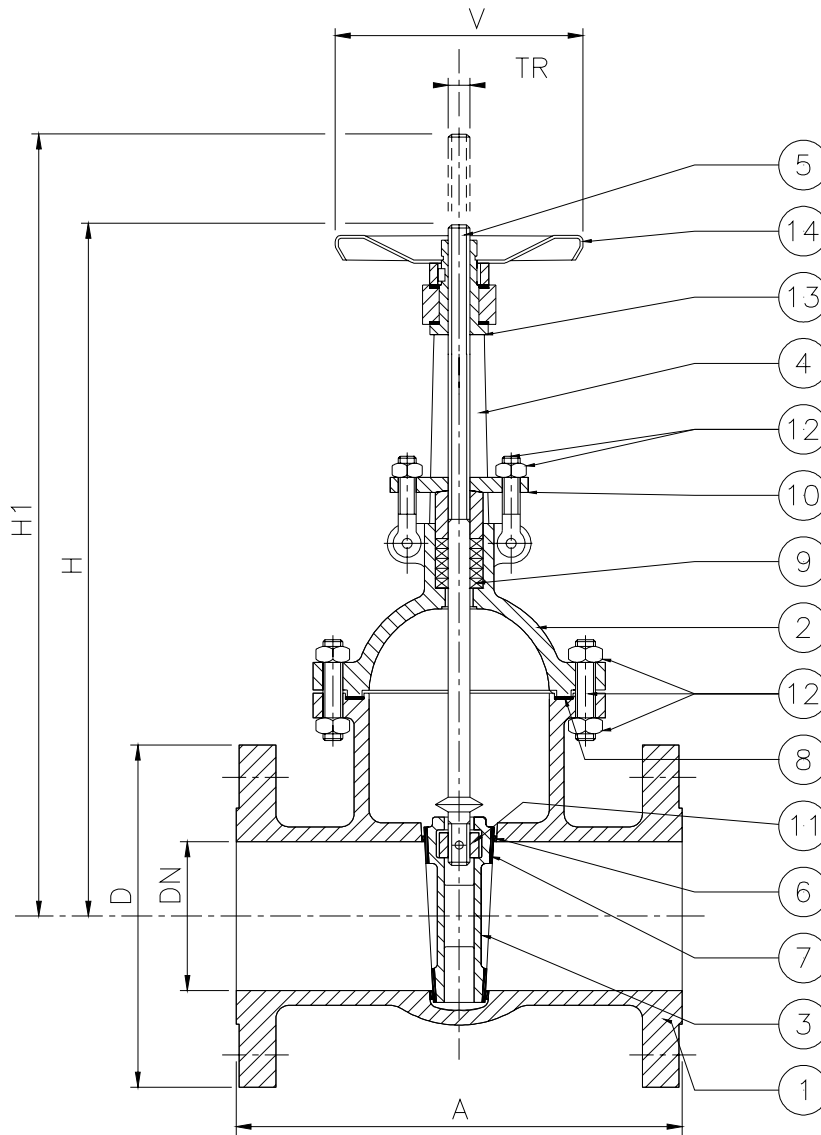

0948

Rel. 5.0

Standard features:

- Design EN 12516
EN 1984
- Face to face EN 558 series 26
DIN 3202 F7
- Flanges EN 1092-1/21/B2
- Materials EN 10213
EN 10269
EN 10088
- Bolts and nuts EN 1515-1
- Welding overlay AD-M HP 0
- Testing EN 1984
EN 12266
- Marking EN 19
- Certificates EN 10204

Optional versions:

- AD 2000 – A4
- TRD 110
- DIN 3230 Part 4
- DIN 3230 Part 5
- DIN 3230 Part 6
- TRbF 131
- TRbF 301 or 302
- ATEX
- TA-Luft
- With flanges PN 63
- With flanges form A, B2, C, D, E, F, G, H
- With butt welding ends (EN 12982 / EN 12627)
- With special devices (see pages 34 – 35)

	DESCRIPTION	FIG. 260	FIG. 360	FIG. 360-J	FIG. 460	FIG. 460-H	FIG. 560
1	Body	1.0619	1.4581	1.4308	1.7357	1.7379	1.1138
2	Bonnet	1.0619	1.4581	1.4308	1.7357	1.7379	1.1138
3	x Wedge	1.0619	1.4581	1.4308	1.7357	1.7379	1.1138
4	Yoke	1.0619	1.4581	1.4308	1.7357	1.7379	1.1138
5	x Stem	1.4021 (1)	1.4571 (1)	1.4301 (1)	1.4021 (1)	1.4021 (1)	1.4021 (1)
6	Body seats	1.4502 (2)	1.4430 (2)	1.4316 (2)	1.4502 (2)	Stellite	1.4502 (2)
7	Wedge seats	1.4502 (2)	1.4581 (2)	1.4308 (2)	1.4502 (2)	Stellite	1.4502 (2)
8	O Gasket	Graphite + SS (3)	Graphite + SS (3)	PTFE (3)	Graphite + SS (3)	Graphite + SS (3)	Graphite + SS (3)
9	O Packing	Graphite + SS (3)	Graphite + SS (3)	PTFE (3)	Graphite + SS (3)	Graphite + SS (3)	Graphite + SS (3)
10	x Gland	1.0402	1.4571	1.4301	1.0402	1.0402	1.4301
11	x Boss	1.4571	1.4571	1.4301	1.4571	1.4571	1.4571
12	Bolts	1.7225 (4)	1.4301 (4)	1.4301 (4)	1.7711 (4)	1.7711 (4)	1.7225 (4)
12	Nuts	1.1191 (4)	1.4301 (4)	1.4301 (4)	1.7225 (4)	1.7225 (4)	1.7225 (4)
13	x Yoke sleeve	1.0511 NHT	1.0511 NHT	1.0511 NHT	1.0511 NHT	1.0511 NHT	1.0511 NHT
14	x Handwheel	Pressed steel	Pressed steel	Pressed steel	Pressed steel	Pressed steel	Pressed steel

(1) Also available on request 1.4571, 1.4301, 1.3964, Hastelloy, or other materials.

(2) Also available on request stellite, 1.4462 (duplex), 1.4430, 1.4316, Hastelloy, or other materials.

(3) Also available on request PTFE, Gore-tex, graphite, or other materials and different desing (e.g. cam-profile).

(4) Also available on request 1.7225 / 1.1191, 1.7711 / 1.7225, 1.4401, 1.4301, A4-70 or other materials.

O recommended spare parts for 2 years standard service; x recommended spare parts for 5 years standard service.

Dimensions

	DN	A	D	H	H1	TR	V	Kg	$\Delta p^{(5)}$	Wedge (6)
PN 100	50	250	195	380	440	20 x 4	200	35	100	Split
	65	290	220	520	595	22 x 4	200	70	100	Split
	80	310	230	540	630	24 x 5	250	76	100	Split
	100	350	265	590	700	28 x 5	300	110	100	Split
	125	400	315	770	905	32 x 6	400	144	100	Split
	150	450	355	795	960	32 x 6	400	185	100	Flexible
	200	550	430	1000	1215	36 x 6	400	325	62	Flexible
	250	650	505	1150	1415	40 x 7	500	535	43	Flexible
	300	750	585	1300	1615	60 x 9	600	800	0	Flexible
	400	850	715	1450	1880	100 x 12	600	1250	0	Flexible

(5) Maximum differential pressure for manoeuvre without gear box or by-pass according to EN 12570 (if equal to 0 the gearbox is recommended).

(6) Standard wedge type. Other execution available on request.

Pressure Temperature Ratings (°C / bar)

	PN	-195	-150	-100	-50	-10	0	20	100	150	200	250	300	350	400	425	450	475	500	525	550	575	600	
Fig. 260	100					100	100	98,7	93,3	85,6	77,8	71,1	64,4	60,0	57,8	47,3	36,9							
Fig. 360(7)	100			100	100	100	100	96,4	82,2	76,7	71,1	67,8	64,4	61,1	57,8	56,7	55,6	54,4	53,3	52,2	51,1			
Fig. 360-J	100	100	100	100	100	100	100	94,2	71,1	63,3	55,6	52,2	48,9											
Fig. 460(7)(8)	100					100	100	100	100	100	100	100	100	100	95,6	88,9	86,7	84,4	68,2	52,0	38,2	24,4		
Fig. 460-H(8)	100					100	100	100	100	100	100	100	100	100	100	98,4	96,9	78,7	60,4	44,9	29,3	20,9	12,4	
Fig. 560	100			100	100	100	100	97,8	88,9	84,4	80,0	77,8	75,6											

Please, in the inquiry and in the order, specify always the maximum service temperature when it's over 100 °C.

If the valves are provided with flanged connection PN 63 the maximum allowable pressure should be proportionally reduced.

(7) Suitable over 450 °C only if provided with stellite seats. (8) Suitable over 530 °C only if provided with 1.3964 stem.

General sale and delivery conditions and product guarantee as specified at pages 56 and 57.

Due to constant improvement all data and details contained in this catalogue are purely indicative and they can be subjected to change without notice.

Gate Valve Outside Screw



PN 160 DN 50 - DN 300

PD special ratings for BWE version

Fig. 261-561

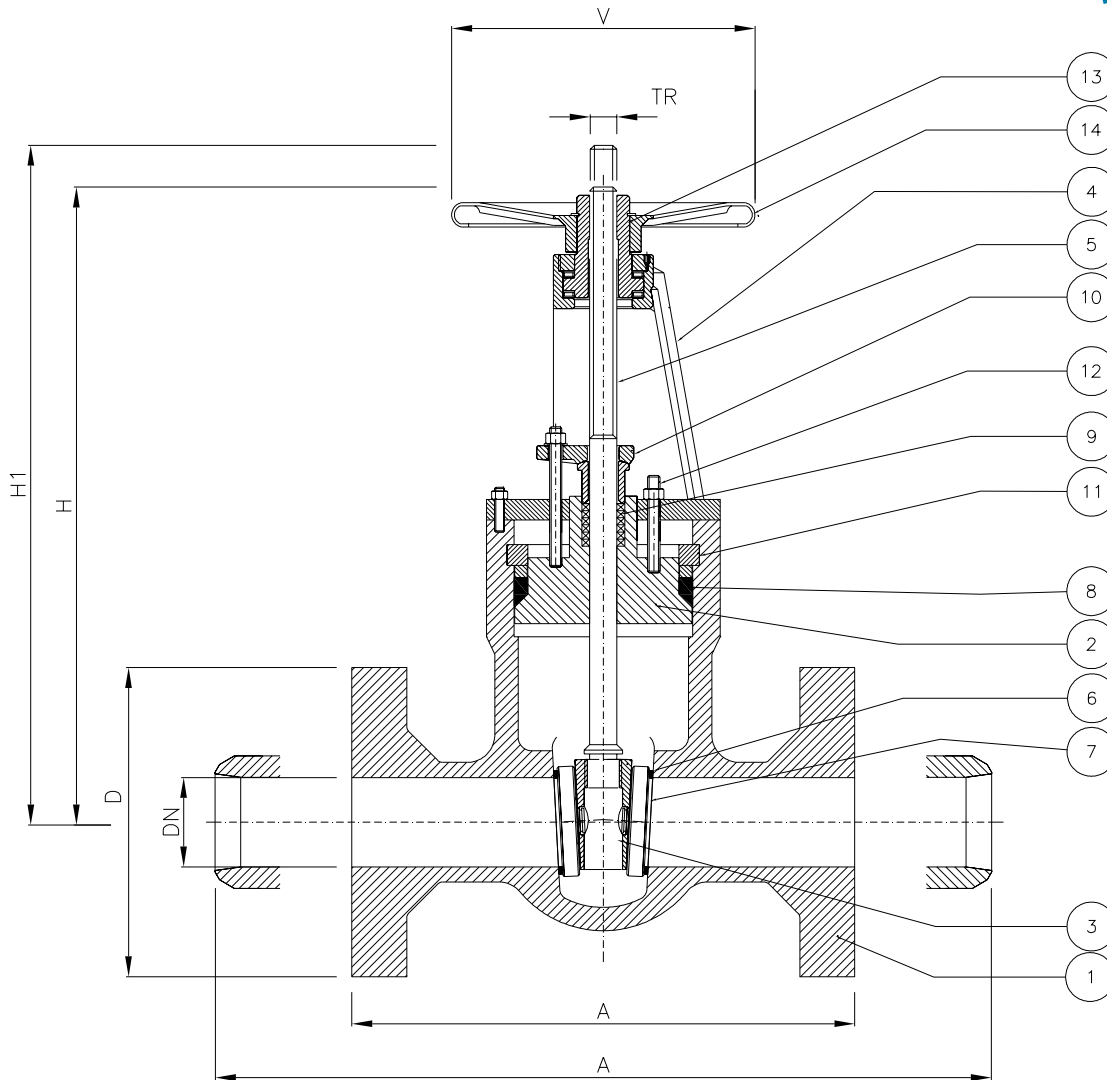

0948

Rel. 5.0

Standard features:

- Design EN 12516
EN 1984
- Face to face EN 558 serie 99
DIN 3202 F8
- With flanges EN 1092-1/21/B2
- Materials EN 10213
EN 10269
EN 10088
- Bolts and nuts EN 1515-1
- Welding overlay AD-M HP 0
- Testing EN 1984
EN 12266
- Marking EN 19
- Certificates EN 10204

Optional versions:

- AD 2000 – A4
- TRD 110
- DIN 3230 Part 4
- DIN 3230 Part 5
- DIN 3230 Part 6
- TRbF 131
- TRbF 301 or 302
- ATEX
- TA-Luft
- With butt welding ends EN 12627 (FTF DIN 3202 S10)
- With flanges form A, B1, B2, C, D, E, F, G, H
- With special devices (see pages 34 – 35)

	DESCRIPTION	FIG. 261	FIG. 361	FIG. 361-J	FIG. 461	FIG. 461-H	FIG. 461-K
1	Body	1.0619	1.4581	1.4308	1.7357	1.7379	1.4931
2	Bonnet	1.0619	1.4581	1.4308	1.7357	1.7379	1.4931
3	x Wedge	1.0425	1.4571	1.4301	1.7335	1.7380	1.4903
4	Yoke	1.0425	1.4571	1.4301	1.7335	1.7380	1.4903
5	x Stem	1.4021 (1)	1.4571 (1)	1.4301 (1)	1.4021 (1)	1.4021 (1)	1.4923 (1)
6	Body seats	1.4502 (2)	1.4430 (2)	1.4316 (2)	1.4502 (2)	Stellite (2)	Stellite (2)
7	Wedge seats	1.4502 (2)	1.4581 (2)	1.4308 (2)	1.4502 (2)	Stellite (2)	Stellite (2)
8	O Gasket	Graphite + SS (3)	Graphite + SS (3)	PTFE (3)	Graphite + SS (3)	Graphite + SS (3)	Graphite + SS (3)
9	O Packing	Graphite + SS (3)	Graphite + SS (3)	PTFE (3)	Graphite + SS (3)	Graphite + SS (3)	Graphite + SS (3)
10	x Gland	1.0402	1.4571	1.4301	1.0402	1.0402	1.0402
11	Segment ring	1.0425	1.4571	1.4301	1.7335	1.7380	1.4903
12	Bolts	1.7225 (4)	1.4301 (4)	1.4301 (4)	1.7711 (4)	1.7711 (4)	1.7225 (4)
12	Nuts	1.1191 (4)	1.4301 (4)	1.4301 (4)	1.7225 (4)	1.7225 (4)	1.7225 (4)
13	x Yoke sleeve	1.0511 NHT	1.0511 NHT	1.0511 NHT	1.0511 NHT	1.0511 NHT	1.0511 NHT
14	x Handwheel	Pressed steel	Pressed steel	Pressed steel	Pressed steel	Pressed steel	Pressed steel

(1) Also available on request 1.4571, 1.4301, 1.3964, Hastelloy, or other materials.

(2) Also available on request stellite, 1.4462 (duplex), 1.4430, 1.4316, Hastelloy, or other materials.

(3) Also available on request PTFE, Gore-tex, graphite, or other materials.

(4) Also available on request 1.7225 / 1.1191, 1.7711 / 1.7225, 1.4401, 1.4301, A4-70 or other materials.

O recommended spare parts for 2 years standard service; x recommended spare parts for 5 years standard service.

Dimensions

PN 160	DN	A	D	H	H1	TR	V	Kg	$\Delta p^{(5)}$	Wedge (6)
	50	300	195	530	600	20 x 4	200	35	240	Split
65	360	220	600	690	22 x 4	200	50	160	Split	
80	390	230	640	730	24 x 5	250	100	160	Split	
100	450	265	750	870	28 x 5	300	130	160	Split	
125	525	315	800	950	36 x 6	400	150	160	Split	
150	600	355	980	1150	40 x 7	400	280	0	Split	
200	750	430	1200	1430	50 x 8	500	520	0	Split	
250	900	515	1400	1680	60 x 9	600	810	0	Split	
300	1050	585	1650	1980	70 x 10	600	1350	0	Split	

(5) Maximum differential pressure for manoeuvre without gear box or by-pass according to EN 12570 (if equal to 0 the gearbox is recommended).

(6) Standard wedge type. Other execution available on request.

Pressure Temperature Ratings (°C / bar)

	PN	-195	-150	-100	-50	-10	0	20	100	150	200	250	300	350	400	425	450	475	500	525	550	575	600	
Fig. 261	160				160	160	157	149	136	124	113	103	96	92	76	59								
Fig. 361(7)	160		160	160	160	160	154	131	122	113	108	103	98	92	91	89	87	85	84	82				
Fig. 361-J	160	160	160	160	160	160	160	150	113	101	89	84	78											
Fig. 461(7)(8)	160				160	160	160	160	160	160	160	160	160	152	142	138	135	109	83	61	39			
Fig. 461-H(8)	160				160	160	160	160	160	160	160	160	160	160	160	160	155	125	97	72	47	33	20	
Fig. 461-K(8)	160				160	160	160	160	160	160	160	160	160	160	160	160	160	160	147	115	84	59	35	

Special ratings for butt welding ends versions only (desing pressure)

	PD	-195	-150	-100	-50	-10	0	20	100	150	200	250	300	350	400	425	450	475	500	525	550	575	600	
Fig. 461-BW(8)	224				224	224	224	224	201	178	171	164	153	142	139	135	109	83	61	39				
Fig. 461-H-BW(8)	284				284	284	284	284	268	252	249	245	235	224	190	155	125	97	72	47	33	20		
Fig. 461-K-BW(8)	384				384	384	384	384	352	320	312	305	291	277	248	219	183	147	115	84	59	35		

Please, in the inquiry and in the order, specify always the maximum service temperature when it's over 100 °C.

If the valves are provided with flanged connection with lower PN the maximum allowable pressure should be proportionally reduced.

(7) Suitable over 450 °C only if provided with stellite seats. (8) Suitable over 530 °C only if provided with 1.3964 stem.

General sale and delivery conditions and product guarantee as specified at pages 56 and 57.

Due to constant improvement all data and details contained in this catalogue are purely indicative and they can be subjected to change without notice.

Gate Valve Outside Screw



PN 250 DN 50 - DN 300

PD special ratings for BWE version

Fig. 266-566

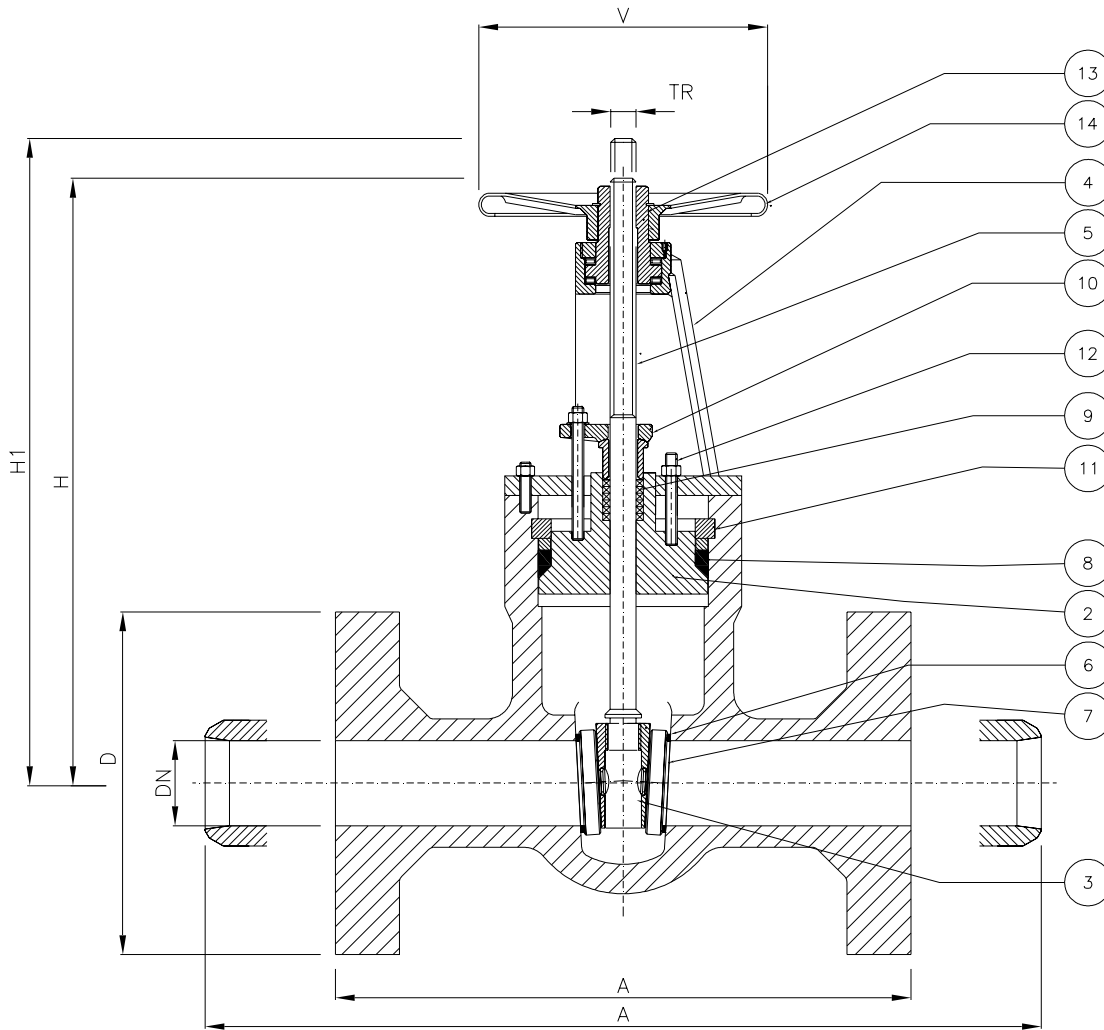

0948

Rel. 5.0

Standard features:

- Design EN 12516
EN 1984
- Face to face EN 558 serie 91
DIN 3202 F9
- With flanges EN 1092-1/21/B2
- Materials EN 10213
EN 10269
EN 10088
- Bolts and nuts EN 1515-1
- Welding overlay AD-M HP 0
- Testing EN 1984
EN 12266
- Marking EN 19
- Certificates EN 10204

Optional versions:

- AD 2000 – A4
- TRD 110
- DIN 3230 Part 4
- DIN 3230 Part 5
- DIN 3230 Part 6
- TRbF 131
- TRbF 301 or 302
- ATEX
- TA-Luft
- With butt welding ends EN 12627
- With flanges form A, B1, B2, C, D, E, F, G, H
- With special devices (see pages 34 – 35)

	DESCRIPTION	FIG. 266	FIG. 366	FIG. 366-J	FIG. 466	FIG. 466-H	FIG. 466-K
1	Body	1.0619	1.4581	1.4308	1.7357	1.7379	1.4931
2	Bonnet	1.0619	1.4581	1.4308	1.7357	1.7379	1.4931
3	x Wedge	1.0425	1.4571	1.4301	1.7335	1.7380	1.4903
4	Yoke	1.0425	1.4571	1.4301	1.7335	1.7380	1.4903
5	x Stem	1.4021 ⁽¹⁾	1.4571 ⁽¹⁾	1.4301 ⁽¹⁾	1.4021 ⁽¹⁾	1.4021 ⁽¹⁾	1.4923 ⁽¹⁾
6	Body seats	1.4502 ⁽²⁾	1.4430 ⁽²⁾	1.4316 ⁽²⁾	1.4502 ⁽²⁾	Stellite ⁽²⁾	Stellite ⁽²⁾
7	Wedge seats	1.4502 ⁽²⁾	1.4581 ⁽²⁾	1.4308 ⁽²⁾	1.4502 ⁽²⁾	Stellite ⁽²⁾	Stellite ⁽²⁾
8	O Gasket	Graphite + SS ⁽³⁾	Graphite + SS ⁽³⁾	PTFE ⁽³⁾	Graphite + SS ⁽³⁾	Graphite + SS ⁽³⁾	Graphite + SS ⁽³⁾
9	O Packing	Graphite + SS ⁽³⁾	Graphite + SS ⁽³⁾	PTFE ⁽³⁾	Graphite + SS ⁽³⁾	Graphite + SS ⁽³⁾	Graphite + SS ⁽³⁾
10	x Gland	1.0402	1.4571	1.4301	1.0402	1.0402	1.0402
11	Segment ring	1.0425	1.4571	1.4301	1.7335	1.7380	1.4903
12	Bolts	1.7225 ⁽⁴⁾	1.4301 ⁽⁴⁾	1.4301 ⁽⁴⁾	1.7711 ⁽⁴⁾	1.7711 ⁽⁴⁾	1.7225 ⁽⁴⁾
12	Nuts	1.1191 ⁽⁴⁾	1.4301 ⁽⁴⁾	1.4301 ⁽⁴⁾	1.7225 ⁽⁴⁾	1.7225 ⁽⁴⁾	1.7225 ⁽⁴⁾
13	x Yoke sleeve	1.0511 NHT	1.0511 NHT	1.0511 NHT	1.0511 NHT	1.0511 NHT	1.0511 NHT
14	x Handwheel	Pressed steel	Pressed steel	Pressed steel	Pressed steel	Pressed steel	Pressed steel

⁽¹⁾ Also available on request 1.4571, 1.4301, 1.3964, Hastelloy, or other materials.

⁽²⁾ Also available on request stellite, 1.4462 (duplex), 1.4430, 1.4316, Hastelloy, or other materials.

⁽³⁾ Also available on request PTFE, Gore-tex, graphite, or other materials.

⁽⁴⁾ Also available on request 1.7225 / 1.1191, 1.7711 / 1.7225, 1.4401, 1.4301, A4-70 or other materials.

O recommended spare parts for 2 years standard service; x recommended spare parts for 5 years standard service.

Dimensions

PN 250	DN	A	D	H	H1	TR	V	Kg	$\Delta p^{(5)}$	Wedge ⁽⁶⁾
	50	350	200	550	600	20 x 4	200	60	240	Split
65	425	230	625	690	22 x 4	250	81	190	Split	
80	470	255	670	750	24 x 5	300	122	160	Split	
100	550	300	790	900	28 x 5	400	170	90	Split	
125	650	340	840	960	40 x 7	500	275	0	Split	
150	750	390	1015	1170	50 x 8	500	390	0	Split	
200	950	485	1260	1480	60 x 9	600	750	0	Split	
250	1150	585	1460	1710	70 x 10	600	1190	0	Split	
300	1350	690	1710	2010	80 x 10	600	1830	0	Split	

⁽⁵⁾ Maximum differential pressure for manoeuvre without gear box or by-pass according to EN 12570 (if equal to 0 the gearbox is recommended).

⁽⁶⁾ Standard wedge type. Other execution available on request.

Pressure Temperature Ratings (°C / bar)

	PN	-195	-150	-100	-50	-10	0	20	100	150	200	250	300	350	400	425	450	475	500	525	550	575	600	
Fig. 266	250				250	250	250	233	214	194	178	161	150	144	118	92								
Fig. 366 ⁽⁷⁾	250		250	250	250	250	250	206	192	178	169	161	153	144	142	139	136	133	131	128				
Fig. 366-J	250	250	250	250	250	250	250	178	158	139	131	122												
Fig. 466 ⁽⁷⁾ ⁽⁸⁾	250				250	250	250	250	250	250	250	250	239	222	217	211	180	130	96	61				
Fig. 466-H ⁽⁸⁾	250				250	250	250	250	250	250	250	250	250	250	246	242	197	151	112	73	52	31		
Fig. 466-K ⁽⁸⁾	250				250	250	250	250	250	250	250	250	250	250	250	250	240	230	181	131	93	54		

Special ratings for butt welding ends versions only (desing pressure)

	PD	-195	-150	-100	-50	-10	0	20	100	150	200	250	300	350	400	425	450	475	500	525	550	575	600	
Fig. 466-BW ⁽⁸⁾	350				350	350	350	350	314	278	267	256	239	222	217	211	171	130	96	61				
Fig. 466-H-BW ⁽⁸⁾	444				444	444	444	444	419	394	389	383	367	350	296	242	197	151	112	73	52	31		
Fig. 466-K-BW ⁽⁸⁾	600				600	600	600	600	550	500	489	478	456	433	388	343	287	230	181	131	93	54		

Please, in the inquiry and in the order, specify always the maximum service temperature when it's over 100 °C.

If the valves are provided with flanged connection PN 100 the maximum allowable pressure should be proportionally reduced.

⁽⁷⁾ Suitable over 450 °C only if provided with stellite seats. ⁽⁸⁾ Suitable over 530 °C only if provided with 1.3964 stem.

General sale and delivery conditions and product guarantee as specified at pages 56 and 57.

Due to constant improvement all data and details contained in this catalogue are purely indicative and they can be subjected to change without notice.

Gate Valve Outside Screw



PN 320 DN 50 - DN 300

PD special ratings for BWE version

Fig. 267-567

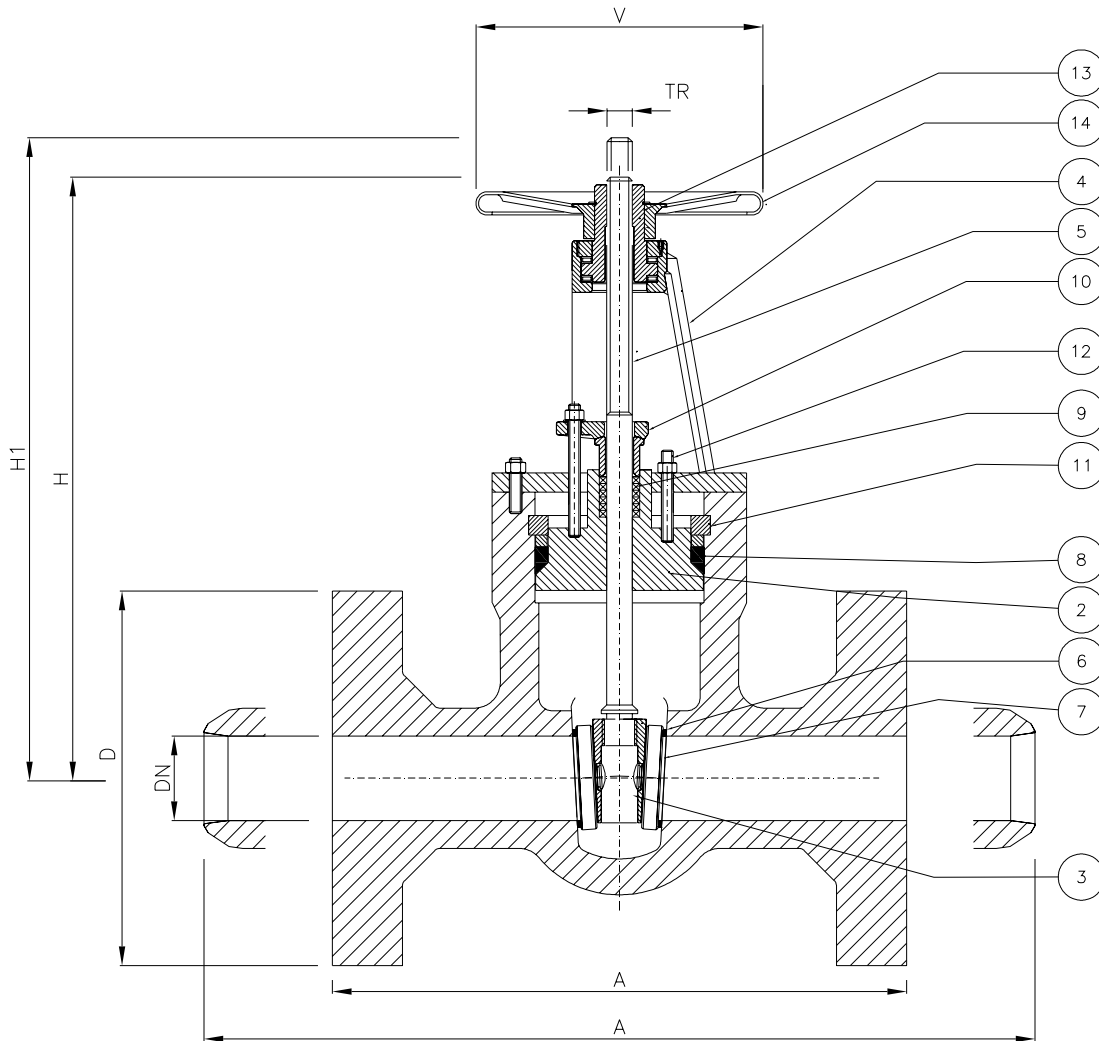

0948

Rel. 5.0

Standard features:

- Design EN 12516
EN 1984
- Face to face EN 558 serie 91
DIN 3202 F9
- With flanges EN 1092-1/21/B2
- Materials EN 10213
EN 10269
EN 10088
- Bolts and nuts EN 1515-1
- Welding overlay AD-M HP 0
- Testing EN 1984
EN 12266
- Marking EN 19
- Certificates EN 10204

Optional versions:

- AD 2000 – A4
- TRD 110
- DIN 3230 Part 4
- DIN 3230 Part 5
- DIN 3230 Part 6
- TRbF 131
- TRbF 301 or 302
- ATEX
- TA-Luft
- With butt welding ends EN 12627
- With flanges form A, B1, B2, C, D, E, F, G, H
- With special devices (see pages 34 – 35)

	DESCRIPTION	FIG. 267	FIG. 367	FIG. 367-J	FIG. 467	FIG. 467-H	FIG. 467-K
1	Body	1.0619	1.4581	1.4308	1.7357	1.7379	1.4931
2	Bonnet	1.0619	1.4581	1.4308	1.7357	1.7379	1.4931
3	x Wedge	1.0425	1.4571	1.4301	1.7335	1.7380	1.4903
4	Yoke	1.0425	1.4571	1.4301	1.7335	1.7380	1.4903
5	x Stem	1.4021 ⁽¹⁾	1.4571 ⁽¹⁾	1.4301 ⁽¹⁾	1.4021 ⁽¹⁾	1.4021 ⁽¹⁾	1.4923 ⁽¹⁾
6	Body seats	1.4502 ⁽²⁾	1.4430 ⁽²⁾	1.4316 ⁽²⁾	1.4502 ⁽²⁾	Stellite ⁽²⁾	Stellite ⁽²⁾
7	Wedge seats	1.4502 ⁽²⁾	1.4581 ⁽²⁾	1.4308 ⁽²⁾	1.4502 ⁽²⁾	Stellite ⁽²⁾	Stellite ⁽²⁾
8	O Gasket	Graphite + SS ⁽³⁾	Graphite + SS ⁽³⁾	PTFE ⁽³⁾	Graphite + SS ⁽³⁾	Graphite + SS ⁽³⁾	Graphite + SS ⁽³⁾
9	O Packing	Graphite + SS ⁽³⁾	Graphite + SS ⁽³⁾	PTFE ⁽³⁾	Graphite + SS ⁽³⁾	Graphite + SS ⁽³⁾	Graphite + SS ⁽³⁾
10	x Gland	1.0402	1.4571	1.4301	1.0402	1.0402	1.0402
11	Segment ring	1.0425	1.4571	1.4301	1.7335	1.7380	1.4903
12	Bolts	1.7225 ⁽⁴⁾	1.4301 ⁽⁴⁾	1.4301 ⁽⁴⁾	1.7711 ⁽⁴⁾	1.7711 ⁽⁴⁾	1.7225 ⁽⁴⁾
12	Nuts	1.1191 ⁽⁴⁾	1.4301 ⁽⁴⁾	1.4301 ⁽⁴⁾	1.7225 ⁽⁴⁾	1.7225 ⁽⁴⁾	1.7225 ⁽⁴⁾
13	x Yoke sleeve	1.0511 NHT	1.0511 NHT	1.0511 NHT	1.0511 NHT	1.0511 NHT	1.0511 NHT
14	x Handwheel	Pressed steel	Pressed steel	Pressed steel	Pressed steel	Pressed steel	Pressed steel

⁽¹⁾ Also available on request 1.4571, 1.4301, 1.3964, Hastelloy, or other materials.

⁽²⁾ Also available on request stellite, 1.4462 (duplex), 1.4430, 1.4316, Hastelloy, or other materials.

⁽³⁾ Also available on request PTFE, Gore-tex, graphite, or other materials.

⁽⁴⁾ Also available on request 1.7225 / 1.1191, 1.7711 / 1.7225, 1.4401, 1.4301, A4-70 or other materials.

O recommended spare parts for 2 years standard service; x recommended spare parts for 5 years standard service.

Dimensions

PN 320	DN	A	D	H	H1	TR	V	Kg	$\Delta p^{(5)}$	Wedge ⁽⁶⁾
	50	350	210	560	610	24 x 5	250	80	160	Split
65	425	255	635	705	28 x 5	300	165	80	Split	
80	470	275	680	760	40 x 7	500	170	30	Split	
100	550	335	800	910	50 x 8	500	260	0	Split	
125	650	380	855	975	60 x 9	600	480	0	Split	
150	750	425	1030	1185	70 x 10	600	670	0	Split	
200	950	525	1280	1500	80 x 10	600	1470	0	Split	
250	1150	640	1490	1740	100 x 12	600	2010	0	Split	
300	1350	780	1750	2060	120 x 14	600	2990	0	Split	

⁽⁵⁾ Maximum differential pressure for manoeuvre without gear box or by-pass according to EN 12570 (if equal to 0 the gearbox is recommended).

⁽⁶⁾ Standard wedge type. Other execution available on request.

Pressure Temperature Ratings (°C / bar)

	PN	-195	-150	-100	-50	-10	0	20	100	150	200	250	300	350	400	425	450	475	500	525	550	575	600
Fig. 267	320				320	320	316	299	274	249	228	206	192	185	151	118							
Fig. 367 ⁽⁷⁾	320			320	320	320	309	263	245	228	217	206	196	185	181	178	174	171	167	164			
Fig. 367-J	320	320	320	320	320	320	302	228	203	178	167	156											
Fig. 467 ⁽⁷⁾ ⁽⁸⁾	320				320	320	320	320	320	320	320	320	320	306	284	277	270	218	166	122	78		
Fig. 467-H ⁽⁸⁾	320				320	320	320	320	320	320	320	320	320	320	320	315	310	252	193	144	94	67	40
Fig. 467-K ⁽⁸⁾	320				320	320	320	320	320	320	320	320	320	320	320	320	320	307	294	231	168	119	70

Special ratings for butt welding ends versions only (desing pressure)

	PD	-195	-150	-100	-50	-10	0	20	100	150	200	250	300	350	400	425	450	475	500	525	550	575	600
Fig. 467-BW ⁽⁸⁾	448				448	448	448	448	402	356	341	327	306	284	277	270	218	166	122	78			
Fig. 467-H-BW ⁽⁸⁾	569				569	569	569	537	505	498	491	469	448	379	310	252	193	144	94	67	40		
Fig. 467-K-BW ⁽⁸⁾	768				768	768	768	768	704	640	626	612	583	555	497	439	367	294	231	168	119	70	

Please, in the inquiry and in the order, specify always the maximum service temperature when it's over 100 °C.

If the valves are provided with flanged connection PN 100 the maximum allowable pressure should be proportionally reduced.

⁽⁷⁾ Suitable over 450 °C only if provided with stellite seats. ⁽⁸⁾ Suitable over 530 °C only if provided with 1.3964 stem.

General sale and delivery conditions and product guarantee as specified at pages 56 and 57.

Due to constant improvement all data and details contained in this catalogue are purely indicative and they can be subjected to change without notice.

Variants & Devices

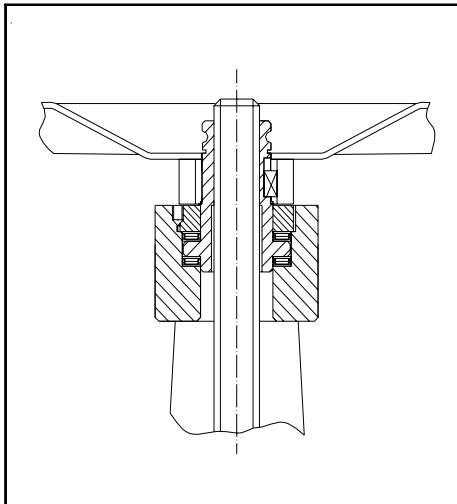

Var. 1000
Top disassembling yoke nut

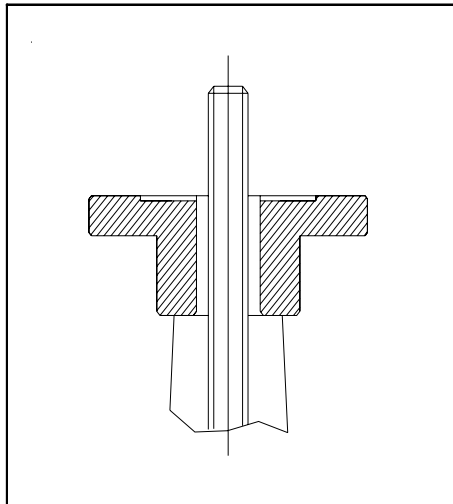

Var. 1010
Top flange acc. to ISO 5210

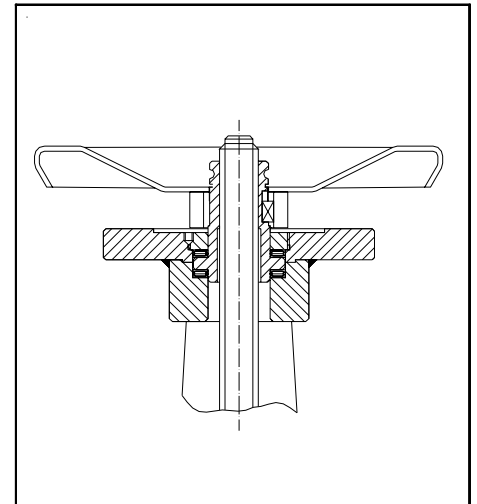

Var. 1015
Convertible top flange acc. to ISO 5210

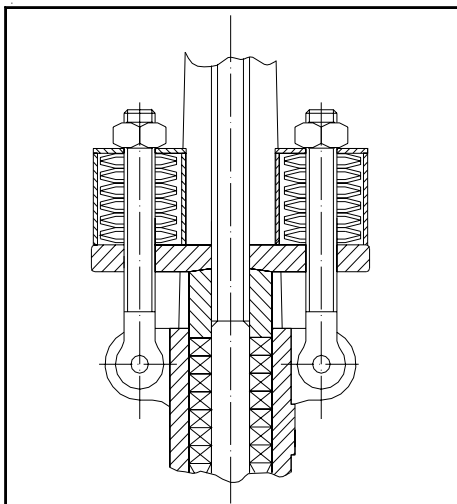

Var. 1020
Live loading packing

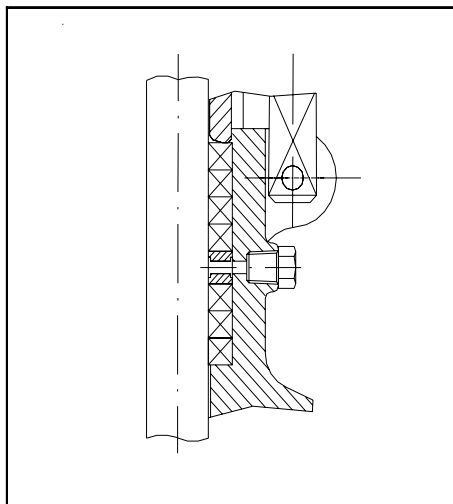

Var. 1025
Lantern ring

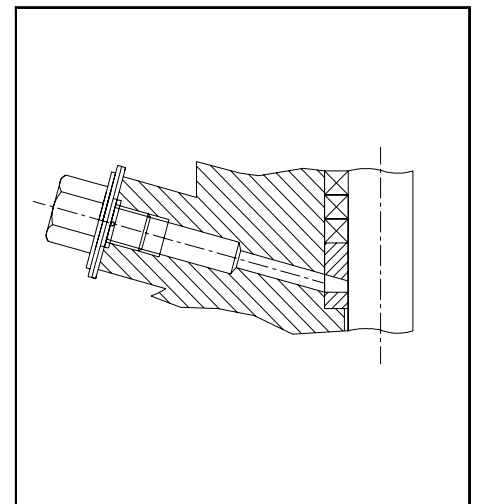

Var. 1030
Packing extraction system

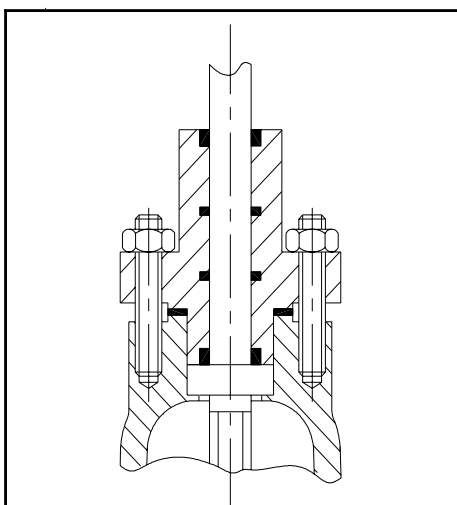

Var. 1040
O - ring packing (inside screw)

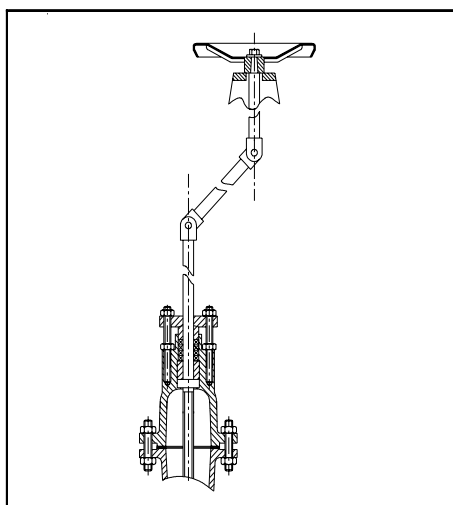

Var. 1050
Stem extension

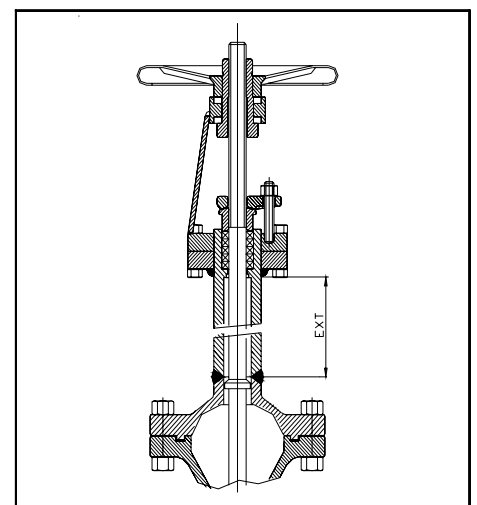

Var. 1060
Cryogenic extension

The drawings of the executions contained in this page are purely indicative, not binding and they can be subjected to change without notice.

Variants & Devices

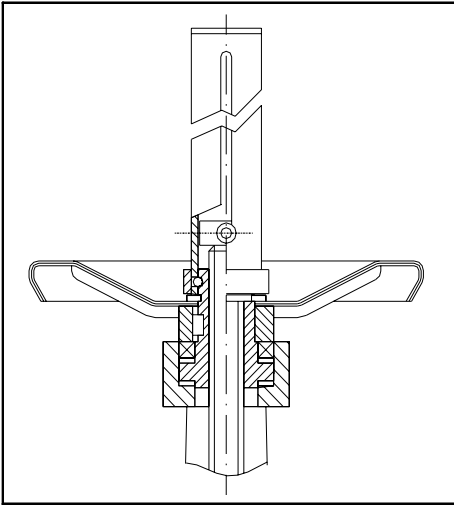

Var. 1110
Position indicator

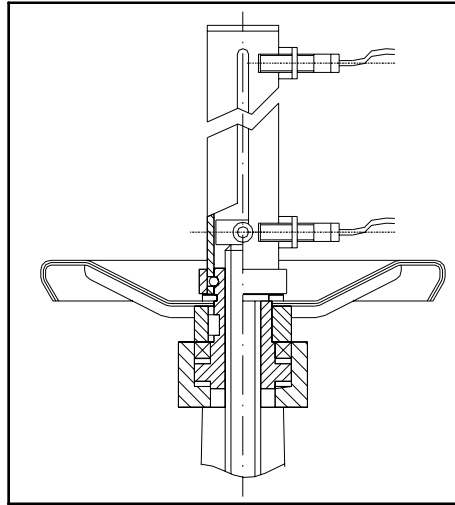

Var. 1120
Position indicator with limit switches

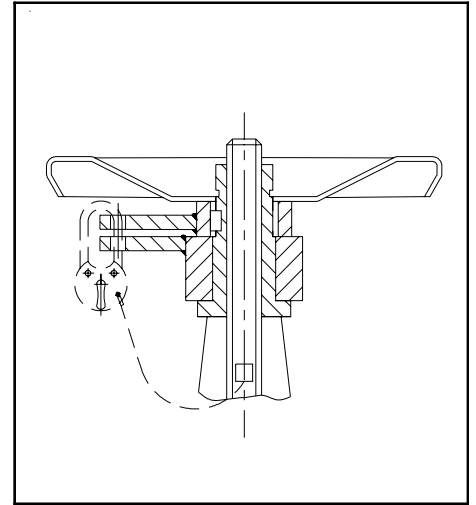

Var. 1130
Locking system

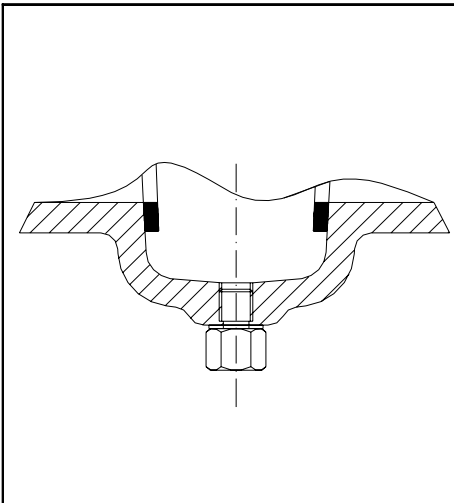

Var. 1200
Drain plug

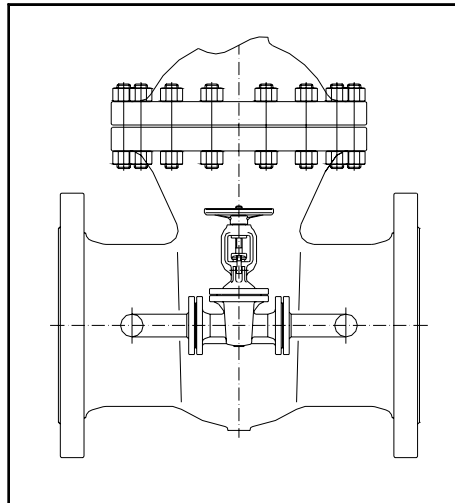

Var. 1300
By pass

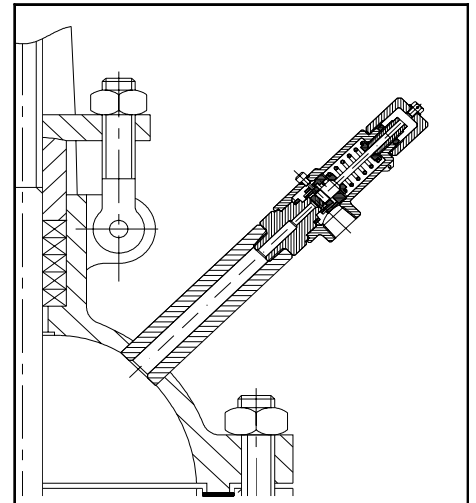

Var. 1400
Pressure relief valve

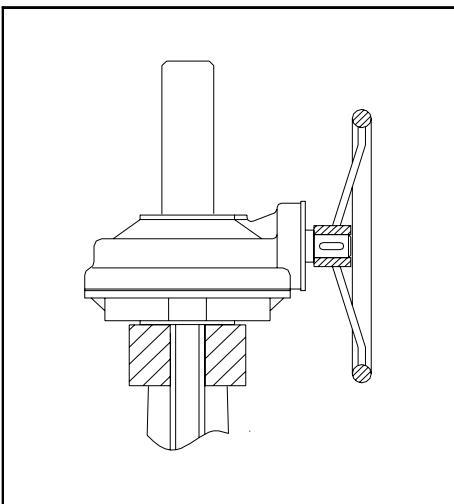

Var. 1510
Bevel gear box

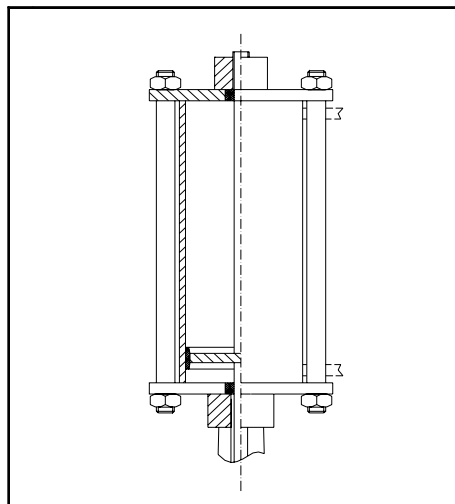

Var. 1520
Pneumatic or hydraulic actuator

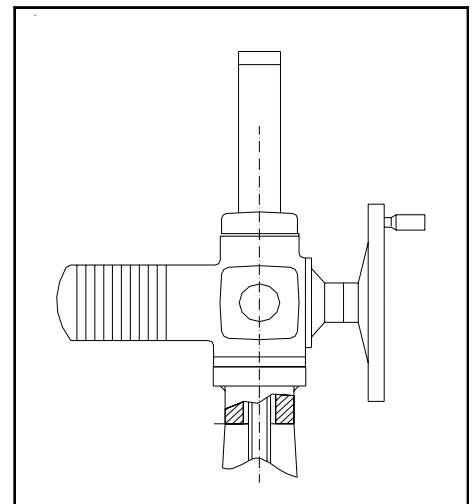

Var. 1530
Electric actuator

The drawings of the executions contained in this page are purely indicative, not binding and they can be subjected to change without notice.

Swing Check Valves

APPLICATIONS

The swing check valves are used to prevent flow reversal in piping systems. The swing check is the most efficient non-return valve due to the minimum pressure drop because of his "full open" design. Typical applications are:

- water
- chemicals
- petrochemicals
- steam
- gases
- liquid gases (cryogenic service)

CONSTRUCTION DETAILS

Body

The body geometry is designed as the result of stress calculations to achieve the most regular distribution of the internal forces due to pressure action.

The body material is high quality cast steel. The seat surface is covered by a wear resistance stainless steel deposited by welding overlay with a hardness difference of +50 HB in comparison with the disk seats. On request the seat surface can be covered also with stellite or other special material overlays.





Cover

The cover is bolted type or pressure seal type for the higher pressures. The cover is produced with forged material similar to the body material.

Besides, the cover is designed and manufactured in order to ensure a perfect seal, as well as to allow an easy disassembly and reassembly work.

Disk

The disk is produced with forged material similar to the body material. A welding overlay of stainless steel material, with high hardness, is deposited on the contact surface. On request the disk can be provided with an overlay of stellite or other materials. The disk - hinge joint is built to achieve a perfect tightness mean a self-positioning system. Also the normal wear is easily recovered by this system that guarantee a prolonged life of the valve with low main-

tenance costs.

Pin

The pin is produced only with special turning machinery for a high resistance and durability.

The pin is produced with a high finish degree and a strict diametrical clearance to reduce the wear at the minimum possible.

Gasket

The standard gasket is in pure graphite stainless steel reinforced. This type of gasket is suitable for many different applications.

For special applications (cryogenic gases, high corrosion acids, etc.) RT can supply special gaskets designed for the specific application or according to customer specifications. All swing check valves are provided by standard with chambered gasket.

Swing Check Valves



Lever and counterweight

On request the swing check valve can be provided with lever with counterweight to balance the weight of the disk and make the closing more soft.

This optional device is suggested for diameters over 200 mm where the weight of the disk is relevant. Also in vertical installation the counterweight can reduce the adverse influence of gravity on the functioning of the swing check valve.

On request the counterweight can be adjustable to be easily adapted to the specific operating conditions.

Hydraulic brake

Where the flow reversal is very quick the swing check valve shall be provided with a hydraulic brake connected to the lever. The brake, lengthening the time of closing to the selected value, avoids the risk that the swing check valve, due to the quick closing of the disk, can cause a water hammer in the pipeline.

Different types of brake are available depending on customer requirements.

All the brakes are provided by a pin valve to set-up the closing time to the required value.

Anti-shock device

When cause a quick closing of a valve or a quick stop of a pump or in any other situation where the pipeline can be subject to water hammers, the swing check valve must be provided with an anti-shock device. The water hammers indeed can give rise strong impacts of the disk against the body seats. This fact generally cause several damaged to the swing check valves and vibrations propagating in the pipeline. The anti-shock device avoids the impacts mean a spring that absorbs all the kinetic energy decelerating quickly the disk. The anti-shock devices are adjustable to be easily adapted to the specific operating conditions.

WARNINGS

- The swing check valves can't be used for media whom tend to produce high sedimentation or encrustation, as well as fluids containing foreign solids that, due to their hardness, present the risk of damage to the seat faces.
- For larger sizes (over DN 200) and frequent opening and closing the lever and counterweight are required to reduce the wear of the components.
- In case of quick flow reversal the swing check valve shall be always provided with lever and brake to avoid causing water hammers.
- When they are possible water hammers caused by other devices, the swing check valve shall be provided

with anti-shock device to avoid damages to the valve and to the pipeline.

- When the swing check valve is provided with lever, appropriate devices shall be predisposed on the installation to avoid the risk of accident for the people due to rapid movement of the lever.

INSTALLATION

The installation position for the swing check valves shall be vertical or horizontal. In case of vertical installation if the direction of the fluid is from the top to down the swing check valve have to be always provided with a counterweight. Before the installation remove the plastic caps from the flanges and verify the correct functioning of the clap. If necessary grease the pin to reduce the friction. Once the medium pressure and temperature are established check the tightness of the bolted connection and of the pin plug: small leakage can be eliminated fastening the bolts. For other information please refer to the installation manual and follow the instructions there contained.

Swing Check Valve

PN 25 DN 50 - DN 600

Flanges PN 25 or PN 16



Fig. 270-570

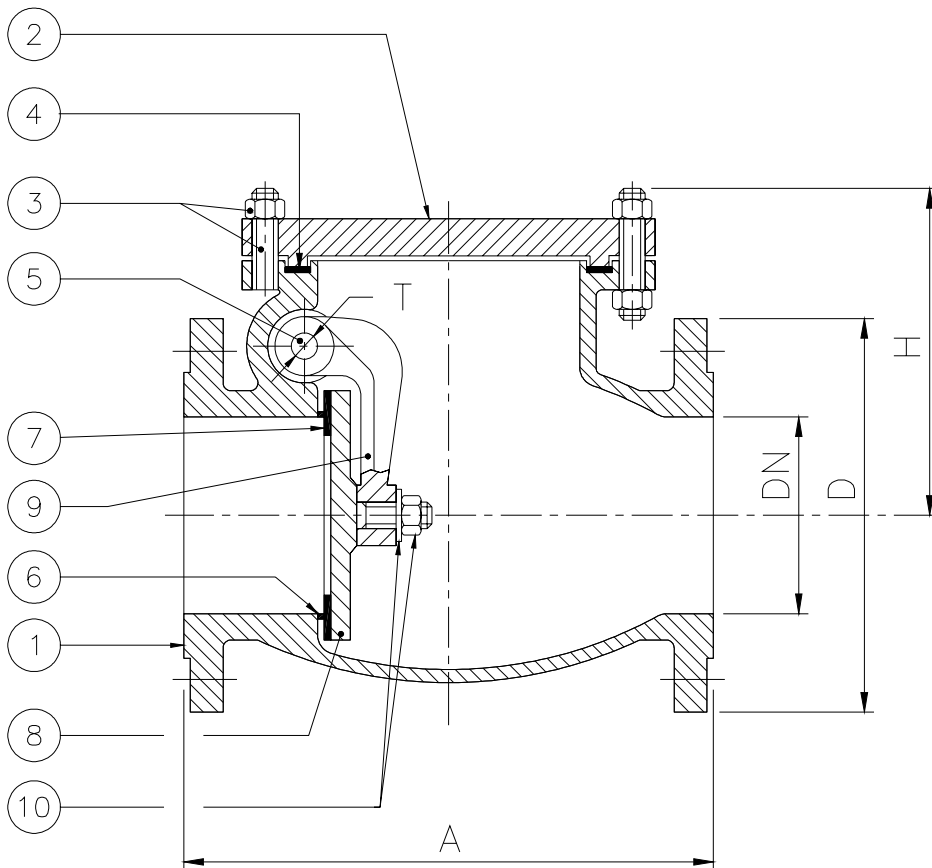

0948

Rel. 5.0

Standard features:

- Design EN 12516
- Face to face EN 558 series 48
DIN 3202 F6
- Flanges EN 1092-1/21/B1
- Materials EN 10213
EN 10269
EN 10088
- Bolts and nuts EN 1515-1
- Welding overlay AD-M HP 0
- Testing EN 12266
- Marking EN 19
- Certificates EN 10204

Optional versions:

- AD 2000 – A4
- TRD 110
- DIN 3230 Part 4
- DIN 3230 Part 5
- DIN 3230 Part 6
- TRbF 131
- TRbF 301 or 302
- ATEX
- TA-Luft
- With flanges PN 10 or PN 6
- With flanges form A, B2, C, D, E, F, G, H
- With butt welding ends (EN 12627)
- With special devices (see page 52)

	DESCRIPTION	FIG. 270	FIG. 370	FIG. 370-J	FIG. 470	FIG. 470-H	FIG. 570
1	Body	1.0619	1.4581	1.4308	1.7357	1.7379	1.1138
2	Cover	1.0425 ⁽⁵⁾	1.4571	1.4301	1.7335	1.7380	1.0508
3	Bolts	1.7225 ⁽⁴⁾	1.4301 ⁽⁴⁾	1.4301 ⁽⁴⁾	1.7711 ⁽⁴⁾	1.7711 ⁽⁴⁾	1.7225 ⁽⁴⁾
3	Nuts	1.1191 ⁽⁴⁾	1.4301 ⁽⁴⁾	1.4301 ⁽⁴⁾	1.7225 ⁽⁴⁾	1.7225 ⁽⁴⁾	1.7225 ⁽⁴⁾
4	O Gasket	Graphite + SS ⁽³⁾	Graphite + SS ⁽³⁾	PTFE ⁽³⁾	Graphite + SS ⁽³⁾	Graphite + SS ⁽³⁾	Graphite + SS ⁽³⁾
5	x Hinge pin	1.4021 ⁽¹⁾	1.4571 ⁽¹⁾	1.4301 ⁽¹⁾	1.4021 ⁽¹⁾	1.4021 ⁽¹⁾	1.4021 ⁽¹⁾
6	Body seats	1.4502 ⁽²⁾	1.4430 ⁽²⁾	1.4316 ⁽²⁾	1.4502 ⁽²⁾	Stellite	1.4502 ⁽²⁾
7	Disk seats	1.4502 ⁽²⁾	1.4571 ⁽²⁾	1.4301 ⁽²⁾	1.4502 ⁽²⁾	Stellite	1.4502 ⁽²⁾
8	x Disk	1.0425 ⁽⁵⁾	1.4571	1.4301	1.7335	1.7380	1.0508
9	Hinge	1.0619	1.4581	1.4308	1.7357	1.7379	1.1138
10	Stud	1.7225 ⁽⁴⁾	1.4401 ⁽⁴⁾	1.4301 ⁽⁴⁾	1.7711 ⁽⁴⁾	1.7711 ⁽⁴⁾	1.7225 ⁽⁴⁾
10	Nut	1.1191 ⁽⁴⁾	1.4401 ⁽⁴⁾	1.4301 ⁽⁴⁾	1.7225 ⁽⁴⁾	1.7225 ⁽⁴⁾	1.7225 ⁽⁴⁾

⁽¹⁾ Also available on request 1,4571, 1.4301, 1.3964, Hastelloy, or other materials.

⁽²⁾ Also available on request stellite, 1.4462 (duplex), 1.4430, 1.4316, Hastelloy, or other materials.

⁽³⁾ Also available on request PTFE, Gore-tex, graphite, or other materials and different desing (e.g. cam-profile).

⁽⁴⁾ Also available on request 1.7225 / 1.1191, 1.7711 / 1.7225, 1.4401, 1.4301, A4-70 or other materials.

⁽⁵⁾ 1.0044 for swing check valves with DN over 125 mm.

O recommended spare parts for 2 years standard service; x recommended spare parts for 5 years standard service.

Dimensions

	DN	A	D	H	T	Kg
PN 25	50	200	165	160	10	15
	65	240	185	170	15	24
	80	260	200	175	15	28
	100	300	235	195	15	38
	125	350	270	210	18	58
	150	400	300	240	18	96
	200	500	360	280	18	131
	250	600	425	320	24	212
	300	700	485	365	24	273
	350	800	555	425	28	440
	400	900	620	440	28	465
	450	1000	670	520	36	750
	500	1100	730	620	36	1100
	600	1300	845	710	40	1500
	700	1500	960	750	50	2100
800	1700	1085	810	60	2800	
900	1900	1185	880	70	3050	

Pressure Temperature Ratings (°C / bar)

	PN	-195	-150	-100	-50	-10	0	20	100	150	200	250	300	350	400	425	450	475	500	525	550	575	600	
Fig. 270 ⁽⁵⁾	25					25.0	25.0	24.7	23.3	21.4	19.4	17.8	16.1	15.0	14.4	11.8	9.2							
Fig. 370 ⁽⁶⁾	25			25.0	25.0	25.0	25.0	24.1	20.6	19.2	17.8	16.9	16.1	15.3	14.4	14.2	13.9	13.6	13.3	13.1	12.8			
Fig. 370-J	25	25.0	25.0	25.0	25.0	25.0	25.0	23.6	17.8	15.8	13.9	13.1	12.2											
Fig. 470 ⁽⁶⁾ / ⁽⁷⁾	25					25.0	25.0	25.0	25.0	25.0	25.0	25.0	23.9	22.2	15.7	9.2	11.1	13.0	9.6	6.1				
Fig. 470-H ⁽⁷⁾	25					25.0	25.0	25.0	25.0	25.0	25.0	25.0	25.0	25.0	24.6	24.2	19.7	15.1	11.2	7.3	5.2	3.1		
Fig. 570	25				25.0	25.0	25.0	24.4	22.2	21.1	20.0	19.4	18.9											

Please, in the inquiry and in the order, specify always the maximum service temperature when it's over 100 °C.

If the valves are provided with flanged connection PN 10 or PN 6 the maximum allowable pressure should be proportionally reduced.

⁽⁵⁾ Supplied suitable for service temperature up to 300°C and for higher temperatures only on request.

⁽⁶⁾ Suitable over 450 °C only if provided with stellite seats. ⁽⁷⁾ Suitable over 530 °C only if provided with 1.3964 pin.

General sale and delivery conditions and product guarantee as specified at pages 56 and 57.

Due to constant improvement all data and details contained in this catalogue are purely indicative and they can be subjected to change without notice.

Swing Check Valve

PN 40 DN 50 - DN 400

Flanges PN 40 or PN 25 or PN 16



Fig. 280-580

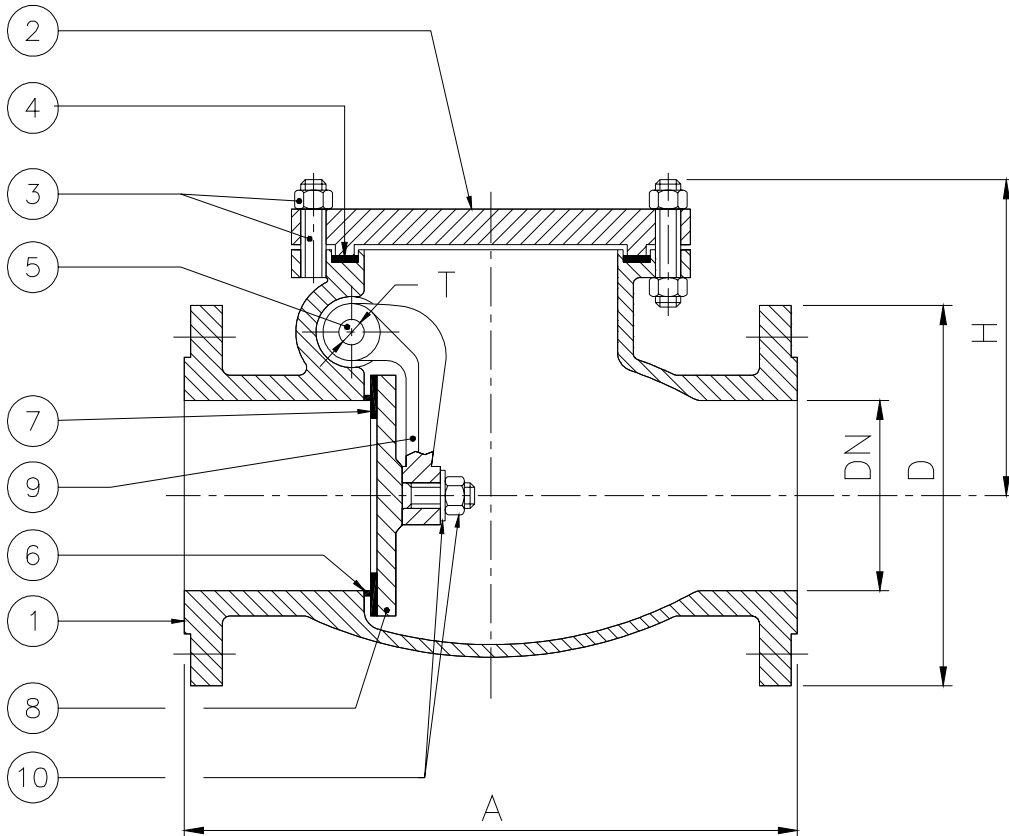

0948

Rel. 5.0

Standard features:

- Design EN 12516
- Face to face EN 558 series 1
DIN 3202 F1
- Flanges EN 1092-1/21/B1
- Materials EN 10213
EN 10269
EN 10088
- Bolts and nuts EN 1515-1
- Welding overlay AD-M HP 0
- Testing EN 12266
- Marking EN 19
- Certificates EN 10204

Optional versions:

- AD 2000 – A4
- TRD 110
- DIN 3230 Part 4
- DIN 3230 Part 5
- DIN 3230 Part 6
- TRbF 131
- TRbF 301 or 302
- ATEX
- TA-Luft
- With flanges PN 10
- With flanges form A, B2, C, D, E, F, G, H
- With butt welding ends (EN 12627 / EN 12982)
- With special devices (see page 52)

	DESCRIPTION	FIG. 280	FIG. 380	FIG. 380-J	FIG. 480	FIG. 480-H	FIG. 580
1	Body	1.0619	1.4581	1.4308	1.7357	1.7379	1.1138
2	Cover	1.0425 ⁽⁵⁾	1.4571	1.4301	1.7335	1.7380	1.0508
3	Bolts	1.7225 ⁽⁴⁾	1.4301 ⁽⁴⁾	1.4301 ⁽⁴⁾	1.7711 ⁽⁴⁾	1.7711 ⁽⁴⁾	1.7225 ⁽⁴⁾
3	Nuts	1.1191 ⁽⁴⁾	1.4301 ⁽⁴⁾	1.4301 ⁽⁴⁾	1.7225 ⁽⁴⁾	1.7225 ⁽⁴⁾	1.7225 ⁽⁴⁾
4	O Gasket	Graphite + SS ⁽³⁾	Graphite + SS ⁽³⁾	PTFE ⁽³⁾	Graphite + SS ⁽³⁾	Graphite + SS ⁽³⁾	Graphite + SS ⁽³⁾
5	x Hinge pin	1.4021 ⁽¹⁾	1.4571 ⁽¹⁾	1.4301 ⁽¹⁾	1.4021 ⁽¹⁾	1.4021 ⁽¹⁾	1.4021 ⁽¹⁾
6	Body seats	1.4502 ⁽²⁾	1.4430 ⁽²⁾	1.4316 ⁽²⁾	1.4502 ⁽²⁾	Stellite	1.4502 ⁽²⁾
7	Disk seats	1.4502 ⁽²⁾	1.4571 ⁽²⁾	1.4301 ⁽²⁾	1.4502 ⁽²⁾	Stellite	1.4502 ⁽²⁾
8	x Disk	1.0425 ⁽⁵⁾	1.4571	1.4301	1.7335	1.7380	1.0508
9	Hinge	1.0619	1.4581	1.4308	1.7357	1.7379	1.1138
10	Stud	1.7225 ⁽⁴⁾	1.4401 ⁽⁴⁾	1.4301 ⁽⁴⁾	1.7711 ⁽⁴⁾	1.7711 ⁽⁴⁾	1.7225 ⁽⁴⁾
10	Nut	1.1191 ⁽⁴⁾	1.4401 ⁽⁴⁾	1.4301 ⁽⁴⁾	1.7225 ⁽⁴⁾	1.7225 ⁽⁴⁾	1.7225 ⁽⁴⁾

⁽¹⁾ Also available on request 1,4571, 1.4301, 1.3964, Hastelloy, or other materials.

⁽²⁾ Also available on request stellite, 1.4462 (duplex), 1.4430, 1.4316, Hastelloy, or other materials.

⁽³⁾ Also available on request PTFE, Gore-tex, graphite, or other materials and different desing (e.g. cam-profile).

⁽⁴⁾ Also available on request 1.7225 / 1.1191, 1.7711 / 1.7225, 1.4401, 1.4301, A4-70 or other materials.

⁽⁵⁾ 1.0044 for swing check valves with DN over 125 mm.

O recommended spare parts for 2 years standard service; x recommended spare parts for 5 years standard service.

Dimensions

	DN	A	D	H	T	Kg
PN 40	50	230	165	160	10	20
	80	310	200	175	15	33
	100	350	235	215	15	46
	125	400	270	230	18	65
	150	480	300	240	18	95
	200	600	375	290	18	165
	250	730	450	320	24	230
	300	850	515	395	24	380
	350	980	580	435	28	500
	400	1100	660	450	28	580

Pressure Temperature Ratings (°C / bar)

	PN	-195	-150	-100	-50	-10	0	20	100	150	200	250	300	350	400	425	450	475	500	525	550	575	600	
Fig. 280 ⁽⁵⁾	40				40.0	40.0	39.5	37.3	34.2	31.1	28.4	25.8	24.0	23.1	18.9	14.8								
Fig. 380 ⁽⁶⁾	40		40.0	40.0	40.0	40.0	38.6	32.9	30.7	28.4	27.1	25.8	24.4	23.1	22.7	22.2	21.8	21.3	20.9	20.4				
Fig. 380-J	40	40.0	40.0	40.0	40.0	40.0	40.0	37.7	28.4	25.3	22.2	20.9	19.6											
Fig. 480 ⁽⁶⁾ ⁽⁷⁾	40				40.0	40.0	40.0	40.0	40.0	40.0	40.0	40.0	40.0	38.2	35.6	25.2	14.8	17.8	20.8	15.3	9.8			
Fig. 480-H ⁽⁷⁾	40				40.0	40.0	40.0	40.0	40.0	40.0	40.0	40.0	40.0	40.0	40.0	39.4	38.8	31.5	24.2	18.0	11.7	8.4	5.0	
Fig. 580	40				40.0	40.0	40.0	39.1	35.6	33.8	32.0	31.1	30.2											

Please, in the inquiry and in the order, specify always the maximum service temperature when it's over 100 °C.

If the valves are provided with flanged connection PN 25 or PN 16 the maximum allowable pressure should be proportionally reduced.

⁽⁵⁾ Supplied suitable for service temperature up to 300°C and for higher temperatures only on request.

⁽⁶⁾ Suitable over 450 °C only if provided with stellite seats. ⁽⁷⁾ Suitable over 530 °C only if provided with 1.3964 pin.

General sale and delivery conditions and product guarantee as specified at pages 56 and 57.

Due to constant improvement all data and details contained in this catalogue are purely indicative and they can be subjected to change without notice.

Swing Check Valve

PN 100 DN 50 - DN 400

Flanges PN 100 or PN 63



Fig. 290-590

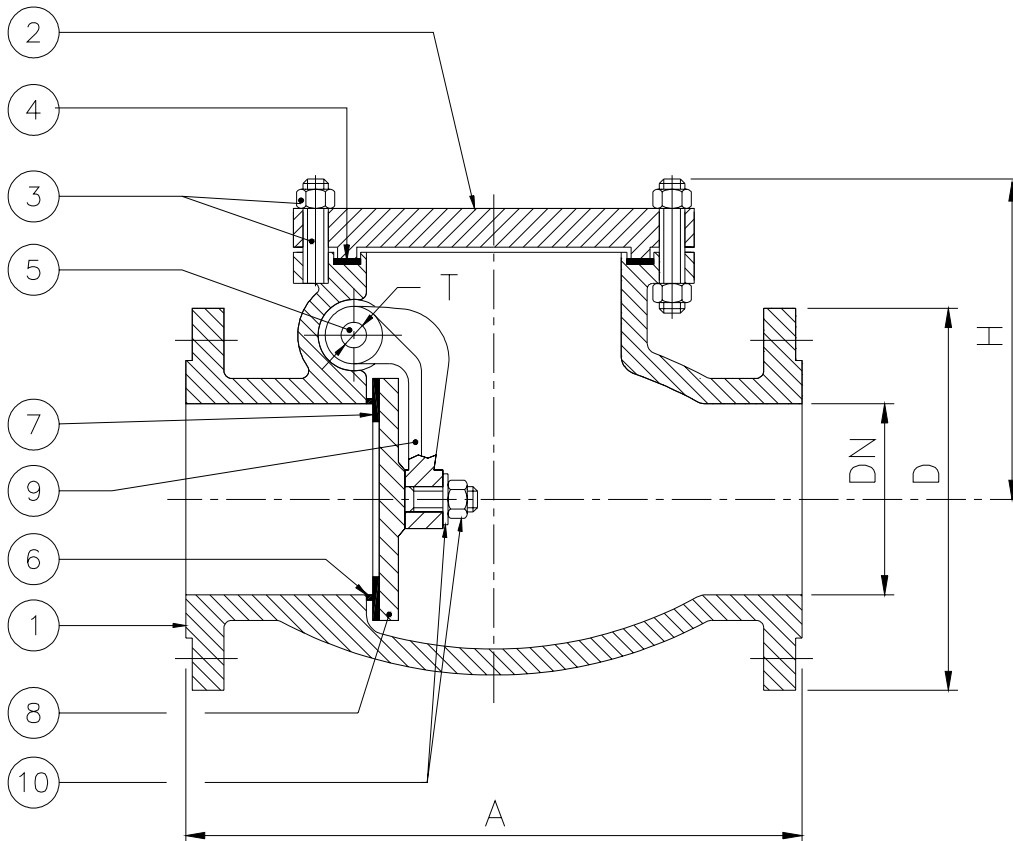

0948

Rel. 5.0

Standard features:

- Design EN 12516
- Face to face EN 558 series 2
DIN 3202 F2
- Flanges EN 1092-1/21/B2
- Materials EN 10213
EN 10269
EN 10088
- Bolts and nuts EN 1515-1
- Welding overlay AD-M HP 0
- Testing EN 12266
- Marking EN 19
- Certificates EN 10204

Optional versions:

- AD 2000 – A4
- TRD 110
- DIN 3230 Part 4
- DIN 3230 Part 5
- DIN 3230 Part 6
- TRbF 131
- TRbF 301 or 302
- ATEX
- TA-Luft
- With flanges PN 40 or PN25
- With flanges form A, B1, C, D, E, F, G, H
- With butt welding ends (EN 12627 / EN 12982)
- With special devices (see page 52)

	DESCRIPTION	FIG. 290	FIG. 390	FIG. 390-J	FIG. 490	FIG. 490-H	FIG. 590
1	Body	1.0619	1.4581	1.4308	1.7357	1.7379	1.1138
2	Cover	1.0425 ⁽⁵⁾	1.4571	1.4301	1.7335	1.7380	1.0508
3	Bolts	1.7225 ⁽⁴⁾	1.4301 ⁽⁴⁾	1.4301 ⁽⁴⁾	1.7711 ⁽⁴⁾	1.7711 ⁽⁴⁾	1.7225 ⁽⁴⁾
3	Nuts	1.1191 ⁽⁴⁾	1.4301 ⁽⁴⁾	1.4301 ⁽⁴⁾	1.7225 ⁽⁴⁾	1.7225 ⁽⁴⁾	1.7225 ⁽⁴⁾
4	O Gasket	Graphite + SS ⁽³⁾	Graphite + SS ⁽³⁾	PTFE ⁽³⁾	Graphite + SS ⁽³⁾	Graphite + SS ⁽³⁾	Graphite + SS ⁽³⁾
5	x Hinge pin	1.4021 ⁽¹⁾	1.4571 ⁽¹⁾	1.4301 ⁽¹⁾	1.4021 ⁽¹⁾	1.4021 ⁽¹⁾	1.4021 ⁽¹⁾
6	Body seats	1.4502 ⁽²⁾	1.4430 ⁽²⁾	1.4316 ⁽²⁾	1.4502 ⁽²⁾	Stellite ⁽²⁾	1.4502 ⁽²⁾
7	Disk seats	1.4502 ⁽²⁾	1.4571 ⁽²⁾	1.4301 ⁽²⁾	1.4502 ⁽²⁾	Stellite ⁽²⁾	1.4502 ⁽²⁾
8	x Disk	1.0425 ⁽⁵⁾	1.4571	1.4301	1.7335	1.7380	1.0508
9	Hinge	1.0619	1.4581	1.4308	1.7357	1.7379	1.1138
10	Stud	1.7225 ⁽⁴⁾	1.4401 ⁽⁴⁾	1.4301 ⁽⁴⁾	1.7711 ⁽⁴⁾	1.7711 ⁽⁴⁾	1.7225 ⁽⁴⁾
10	Nut	1.1191 ⁽⁴⁾	1.4401 ⁽⁴⁾	1.4301 ⁽⁴⁾	1.7225 ⁽⁴⁾	1.7225 ⁽⁴⁾	1.7225 ⁽⁴⁾

⁽¹⁾ Also available on request 1,4571, 1.4301, 1.3964, Hastelloy, or other materials.

⁽²⁾ Also available on request stellite, 1.4462 (duplex), 1.4430, 1.4316, Hastelloy, or other materials.

⁽³⁾ Also available on request PTFE, Gore-tex, graphite, or other materials and different desing (e.g. cam-profile).

⁽⁴⁾ Also available on request 1.7225 / 1.1191, 1.7711 / 1.7225, 1.4401, 1.4301, A4-70 or other materials.

⁽⁵⁾ 1.0044 for swing check valves with DN over 125 mm.

O recommended spare parts for 2 years standard service; x recommended spare parts for 5 years standard service.

Dimensions

	DN	A	D	H	T	Kg
PN 100	50	300	195	175	10	25
	80	380	230	200	15	40
	100	430	265	245	15	60
	125	500	315	260	18	100
	150	550	355	275	18	130
	200	650	400	315	24	200
	250	775	515	360	24	260
	300	900	585	415	24	420
	350	1025	655	620	28	910
	400	1150	715	700	28	1200

Pressure Temperature Ratings (°C / bar)

	PN	-195	-150	-100	-50	-10	0	20	100	150	200	250	300	350	400	425	450	475	500	525	550	575	600	
Fig. 290 ⁽⁵⁾	100								98,7	93,3	85,6	77,8	71,1	64,4	60,0	57,8	47,3	36,9						
Fig. 390 ⁽⁶⁾	100			100	100	100	100	100	96,4	82,2	76,7	71,1	67,8	64,4	61,1	57,8	56,7	55,6	54,4	53,3	52,2	51,1		
Fig. 390-J	100	100	100	100	100	100	100	100	94,2	71,1	63,3	55,6	52,2	48,9										
Fig. 490 ⁽⁶⁾ / ⁽⁷⁾	100					100	100	100	100	100	100	100	100	100	95,6	88,9	86,7	84,4	68,2	52,0	38,2	24,4		
Fig. 490-H ⁽⁷⁾	100					100	100	100	100	100	100	100	100	100	100	98,4	96,9	78,7	60,4	44,9	29,3	20,9	12,4	
Fig. 590	100			100	100	100	100	97,8	88,9	84,4	80,0	77,8	75,6											

Please, in the inquiry and in the order, specify always the maximum service temperature when it's over 100 °C.

If the valves are provided with flanged connection PN 63 the maximum allowable pressure should be proportionally reduced.

⁽⁵⁾ Supplied suitable for service temperature up to 300°C and for higher temperatures only on request.

⁽⁶⁾ Suitable over 450 °C only if provided with stellite seats. ⁽⁷⁾ Suitable over 530 °C only if provided with 1.3964 pin.

General sale and delivery conditions and product guarantee as specified at pages 56 and 57.

Due to constant improvement all data and details contained in this catalogue are purely indicative and they can be subjected to change without notice.

Swing Check Valve

PN 160 DN 50 - DN 300

PD special ratings for BWE version



Fig. 291-591

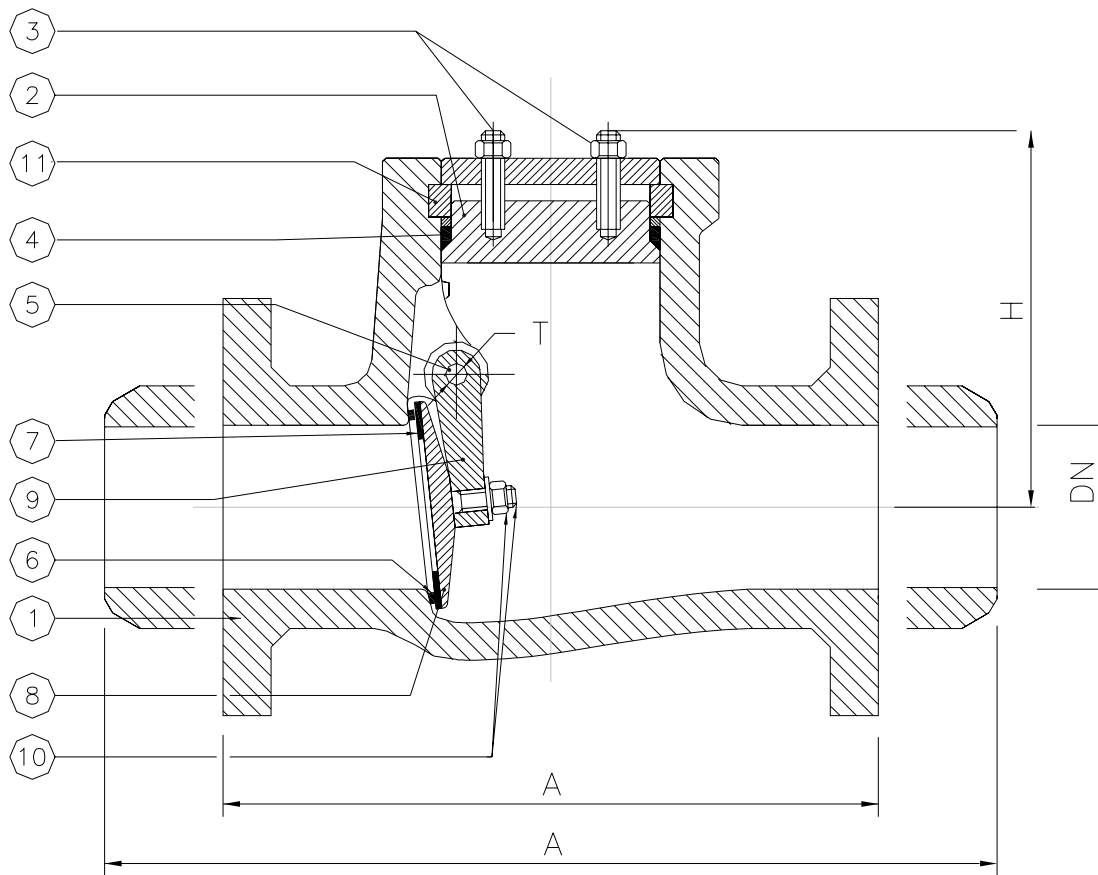

0948

Rel. 5.0

Standard features:

- Design EN 12516
EN 14341
- Face to face EN 558 series 99
DIN 3202 F8
- With flanges EN 1092-1/21/B2
- Materials EN 10213
EN 10269
EN 10088
- Bolts and nuts EN 1515-1
- Welding overlay AD-M HP 0
- Testing EN 12266
- Marking EN 19
- Certificates EN 10204

Optional versions:

- AD 2000 – A4
- TRD 110
- DIN 3230 Part 4
- DIN 3230 Part 5
- DIN 3230 Part 6
- TRbF 131
- TRbF 301 or 302
- ATEX
- TA-Luft
- With butt welding ends EN 12627
- With flanges form A, B1, B2, C, D, E, F, G, H
- With special devices (see page 52)

	DESCRIPTION	FIG. 291	FIG. 391	FIG. 391-J	FIG. 491	FIG. 491-H	FIG. 491-K
1	Body	1.0619	1.4581	1.4308	1.7357	1.7379	1.4931
2	Cover	1.0425 ⁽⁵⁾	1.4571	1.4301	1.7335	1.7380	1.4931
3	Bolts	1.7225 ⁽⁴⁾	1.4301 ⁽⁴⁾	1.4301 ⁽⁴⁾	1.7711 ⁽⁴⁾	1.7711 ⁽⁴⁾	1.7225 ⁽⁴⁾
3	Nuts	1.1191 ⁽⁴⁾	1.4301 ⁽⁴⁾	1.4301 ⁽⁴⁾	1.7225 ⁽⁴⁾	1.7225 ⁽⁴⁾	1.7225 ⁽⁴⁾
4	O Gasket	Graphite + SS ⁽³⁾	Graphite + SS ⁽³⁾	PTFE ⁽³⁾	Graphite + SS ⁽³⁾	Graphite + SS ⁽³⁾	Graphite + SS ⁽³⁾
5	X Hinge pin	1.4021 ⁽¹⁾	1.4571 ⁽¹⁾	1.4301 ⁽¹⁾	1.4021 ⁽¹⁾	1.4021 ⁽¹⁾	1.4923 ⁽¹⁾
6	Body seats	1.4502 ⁽²⁾	1.4581 ⁽²⁾	1.4308 ⁽²⁾	1.4502 ⁽²⁾	Stellite ⁽²⁾	Stellite ⁽²⁾
7	Disk seats	1.4502 ⁽²⁾	1.4430 ⁽²⁾	1.4301 ⁽²⁾	1.4502 ⁽²⁾	Stellite ⁽²⁾	Stellite ⁽²⁾
8	X Disk	1.0425 ⁽⁵⁾	1.4571	1.4301	1.7335	1.7380	1.4903
9	Hinge	1.0619	1.4581	1.4308	1.7357	1.7379	1.4903
10	Stud	1.7225 ⁽⁴⁾	1.4401 ⁽⁴⁾	1.4301 ⁽⁴⁾	1.7711 ⁽⁴⁾	1.7711 ⁽⁴⁾	1.7225 ⁽⁴⁾
10	Nut	1.1191 ⁽⁴⁾	1.4401 ⁽⁴⁾	1.4301 ⁽⁴⁾	1.7225 ⁽⁴⁾	1.7225 ⁽⁴⁾	1.7225 ⁽⁴⁾
11	Segmented ring	1.0425 ⁽⁵⁾	1.4571	1.4301	1.7335	1.7380	1.4903

⁽¹⁾ Also available on request 1.4571, 1.4301, 1.3964, Hastelloy, or other materials.

⁽²⁾ Also available on request stellite, 1.4462 (duplex), 1.4430, 1.4316, Hastelloy, or other materials.

⁽³⁾ Also available on request PTFE, Gore-tex, graphite, or other materials.

⁽⁴⁾ Also available on request 1.7225 / 1.1191, 1.7711 / 1.7225, 1.4401, 1.4301, A4-70 or other materials.

⁽⁵⁾ 1.0044 for swing check valves with DN over 125 mm.

O recommended spare parts for 2 years standard service; x recommended spare parts for 5 years standard service.

Dimensions

	DN	A	D	H	T	Kg
PN 160	50	300	195	175	10	45
	80	390	230	205	15	65
	100	450	265	270	15	90
	125	525	315	305	18	150
	150	600	355	320	18	190
	200	750	430	410	18	360
	250	900	515	490	24	540
	300	1050	585	550	24	780

Pressure Temperature Ratings (°C / bar)

	PN	-195	-150	-100	-50	-10	0	20	100	150	200	250	300	350	400	425	450	475	500	525	550	575	600	
Fig. 291 ⁽⁶⁾	160					160	160	157	149	136	124	113	103	96	92	76	59							
Fig. 391 ⁽⁷⁾	160			160	160	160	160	154	131	122	113	108	103	98	92	91	89	87	85	84	82			
Fig. 391-J	160	160	160	160	160	160	160	150	113	101	89	84	78											
Fig. 491 ⁽⁸⁾	160					160	160	160	160	160	160	160	160	152	142	138	135	109	83	61	39			
Fig. 491-H ⁽⁸⁾	160					160	160	160	160	160	160	160	160	160	160	160	155	125	97	72	47	33	20	
Fig. 491-K ⁽⁸⁾	160					160	160	160	160	160	160	160	160	160	160	160	160	160	160	147	115	84	59	35

Special ratings for butt welding ends versions only (desing pressure)

	PD	-195	-150	-100	-50	-10	0	20	100	150	200	250	300	350	400	425	450	475	500	525	550	575	600	
Fig. 461-BW ⁽⁸⁾	224					224	224	224	224	201	178	171	164	153	142	139	135	109	83	61	39			
Fig. 461-H-BW ⁽⁸⁾	284					284	284	284	284	268	252	249	245	235	224	190	155	125	97	72	47	33	20	
Fig. 461-K-BW ⁽⁸⁾	384					384	384	384	384	352	320	312	305	291	277	248	219	183	147	115	84	59	35	

Please, in the inquiry and in the order, specify always the maximum service temperature when it's over 100 °C.

If the valves are provided with flanged connection with lower PN the maximum allowable pressure should be proportionally reduced.

⁽⁶⁾ Supplied suitable for service temperature up to 300°C and for higher temperatures only on request.

⁽⁷⁾ Suitable over 450 °C only if provided with stellite seats. ⁽⁸⁾ Suitable over 530 °C only if provided with 1.3964 pin.

General sale and delivery conditions and product guarantee as specified at pages 56 and 57.

Due to constant improvement all data and details contained in this catalogue are purely indicative and they can be subjected to change without notice.

Swing Check Valve

PN 250 DN 50 - DN 300

PD special ratings for BWE version



Fig. 296-596

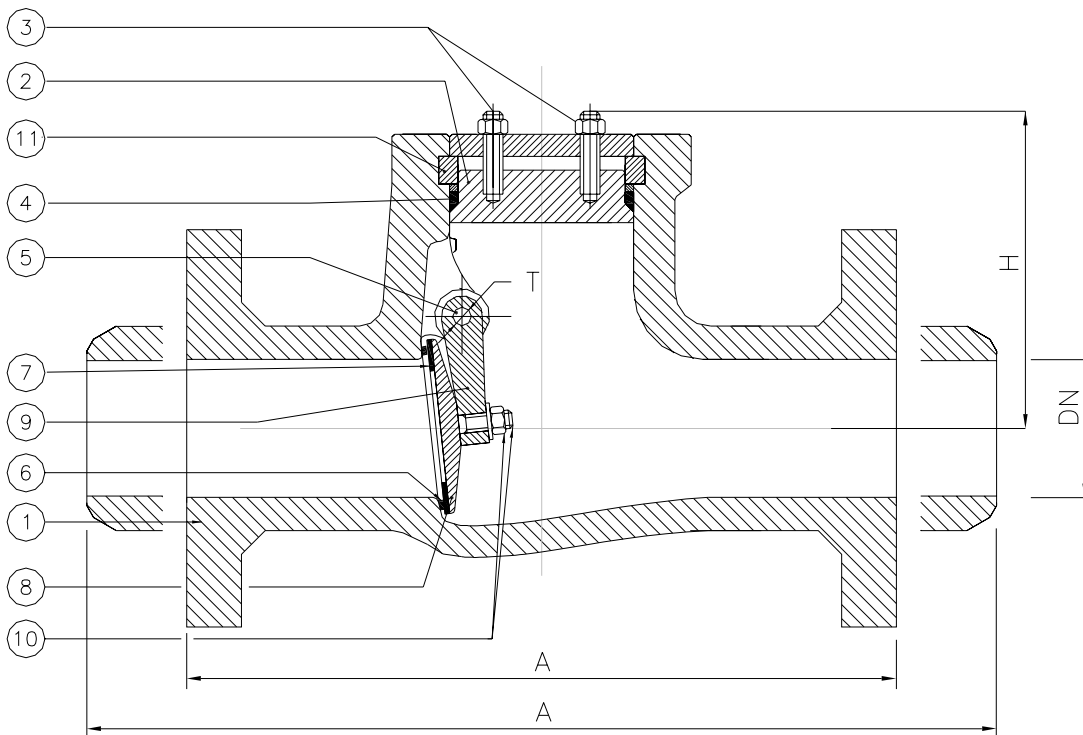

0948

Rel. 5.0

Standard features:

- Design EN 12516
EN 14341
- Face to face EN 558 series 91
DIN 3202 F9
- With flanges EN 1092-1/21/B2
- Materials EN 10213
EN 10269
EN 10088
- Bolts and nuts EN 1515-1
- Welding overlay AD-M HP 0
- Testing EN 12266
- Marking EN 19
- Certificates EN 10204

Optional versions:

- AD 2000 – A4
- TRD 110
- DIN 3230 Part 4
- DIN 3230 Part 5
- DIN 3230 Part 6
- TRbF 131
- TRbF 301 or 302
- ATEX
- TA-Luft
- With butt welding ends EN 12627
- With flanges form A, B1, B2, C, D, E, F, G, H
- With special devices (see page 52)

	DESCRIPTION	FIG. 296	FIG. 396	FIG. 396-J	FIG. 496	FIG. 496-H	FIG. 496-K
1	Body	1.0619	1.4581	1.4308	1.7357	1.7379	1.4931
2	Cover	1.0425 ⁽⁵⁾	1.4571	1.4301	1.7335	1.7380	1.4931
3	Bolts	1.7225 ⁽⁴⁾	1.4301 ⁽⁴⁾	1.4301 ⁽⁴⁾	1.7711 ⁽⁴⁾	1.7711 ⁽⁴⁾	1.7225 ⁽⁴⁾
3	Nuts	1.1191 ⁽⁴⁾	1.4301 ⁽⁴⁾	1.4301 ⁽⁴⁾	1.7225 ⁽⁴⁾	1.7225 ⁽⁴⁾	1.7225 ⁽⁴⁾
4	O Gasket	Graphite + SS ⁽³⁾	Graphite + SS ⁽³⁾	PTFE ⁽³⁾	Graphite + SS ⁽³⁾	Graphite + SS ⁽³⁾	Graphite + SS ⁽³⁾
5	X Hinge pin	1.4021 ⁽¹⁾	1.4571 ⁽¹⁾	1.4301 ⁽¹⁾	1.4021 ⁽¹⁾	1.4021 ⁽¹⁾	1.4923 ⁽¹⁾
6	Body seats	1.4502 ⁽²⁾	1.4581 ⁽²⁾	1.4308 ⁽²⁾	1.4502 ⁽²⁾	Stellite ⁽²⁾	Stellite ⁽²⁾
7	Disk seats	1.4502 ⁽²⁾	1.4430 ⁽²⁾	1.4301 ⁽²⁾	1.4502 ⁽²⁾	Stellite ⁽²⁾	Stellite ⁽²⁾
8	X Disk	1.0425 ⁽⁵⁾	1.4571	1.4301	1.7335	1.7380	1.4903
9	Hinge	1.0619	1.4581	1.4308	1.7357	1.7379	1.4903
10	Stud	1.7225 ⁽⁴⁾	1.4401 ⁽⁴⁾	1.4301 ⁽⁴⁾	1.7711 ⁽⁴⁾	1.7711 ⁽⁴⁾	1.7225 ⁽⁴⁾
10	Nut	1.1191 ⁽⁴⁾	1.4401 ⁽⁴⁾	1.4301 ⁽⁴⁾	1.7225 ⁽⁴⁾	1.7225 ⁽⁴⁾	1.7225 ⁽⁴⁾
11	Segmented ring	1.0425 ⁽⁵⁾	1.4571	1.4301	1.7335	1.7380	1.4903

⁽¹⁾ Also available on request 1.4571, 1.4301, 1.3964, Hastelloy, or other materials.

⁽²⁾ Also available on request stellite, 1.4462 (duplex), 1.4430, 1.4316, Hastelloy, or other materials.

⁽³⁾ Also available on request PTFE, Gore-tex, graphite, or other materials.

⁽⁴⁾ Also available on request 1.7225 / 1.1191, 1.7711 / 1.7225, 1.4401, 1.4301, A4-70 or other materials.

⁽⁵⁾ 1.0044 for swing check valves with DN over 125 mm.

O recommended spare parts for 2 years standard service; x recommended spare parts for 5 years standard service.

Dimensions

	DN	A	D	H	T	Kg
PN 250	50	350	200	180	10	40
	80	470	255	215	15	80
	100	550	300	285	15	135
	125	650	340	325	18	250
	150	750	390	340	18	310
	200	950	485	435	18	525
	250	1150	585	520	24	830
	300	1350	690	580	24	1250

Pressure Temperature Ratings (°C / bar)

	PN	-195	-150	-100	-50	-10	0	20	100	150	200	250	300	350	400	425	450	475	500	525	550	575	600	
Fig. 296 ⁽⁶⁾	250					250	250	250	233	214	194	178	161	150	144	118	92							
Fig. 396 ⁽⁷⁾	250			250	250	250	250	206	192	178	169	161	153	144	142	139	136	133	131	128				
Fig. 396-J	250	250	250	250	250	250	250	178	158	139	131	122												
Fig. 496 ⁽⁸⁾	250					250	250	250	250	250	250	250	239	222	217	211	180	130	96	61				
Fig. 496-H ⁽⁸⁾	250					250	250	250	250	250	250	250	250	250	246	242	197	151	112	73	52	31		
Fig. 496-K ⁽⁸⁾	250					250	250	250	250	250	250	250	250	250	250	250	240	230	181	131	93	54		

Special ratings for butt welding ends versions only (desing pressure)

	PD	-195	-150	-100	-50	-10	0	20	100	150	200	250	300	350	400	425	450	475	500	525	550	575	600	
Fig. 496-BW ⁽⁸⁾	350					350	350	350	350	314	278	267	256	239	222	217	211	171	130	96	61			
Fig. 496-H-BW ⁽⁸⁾	444					444	444	444	444	419	394	389	383	367	350	296	242	197	151	112	73	52	31	
Fig. 496-K-BW ⁽⁸⁾	600					600	600	600	600	550	500	489	478	456	433	388	343	287	230	181	131	93	54	

Please, in the inquiry and in the order, specify always the maximum service temperature when it's over 100 °C.

If the valves are provided with flanged connection PN 100 the maximum allowable pressure should be proportionally reduced.

⁽⁶⁾ Supplied suitable for service temperature up to 300°C and for higher temperatures only on request.

⁽⁷⁾ Suitable over 450 °C only if provided with stellite seats. ⁽⁸⁾ Suitable over 530 °C only if provided with 1.3964 pin.

General sale and delivery conditions and product guarantee as specified at pages 56 and 57.

Due to constant improvement all data and details contained in this catalogue are purely indicative and they can be subjected to change without notice.

Swing Check Valve

PN 160 DN 50 - DN 300

PD special ratings for BWE version



Fig. 297-597

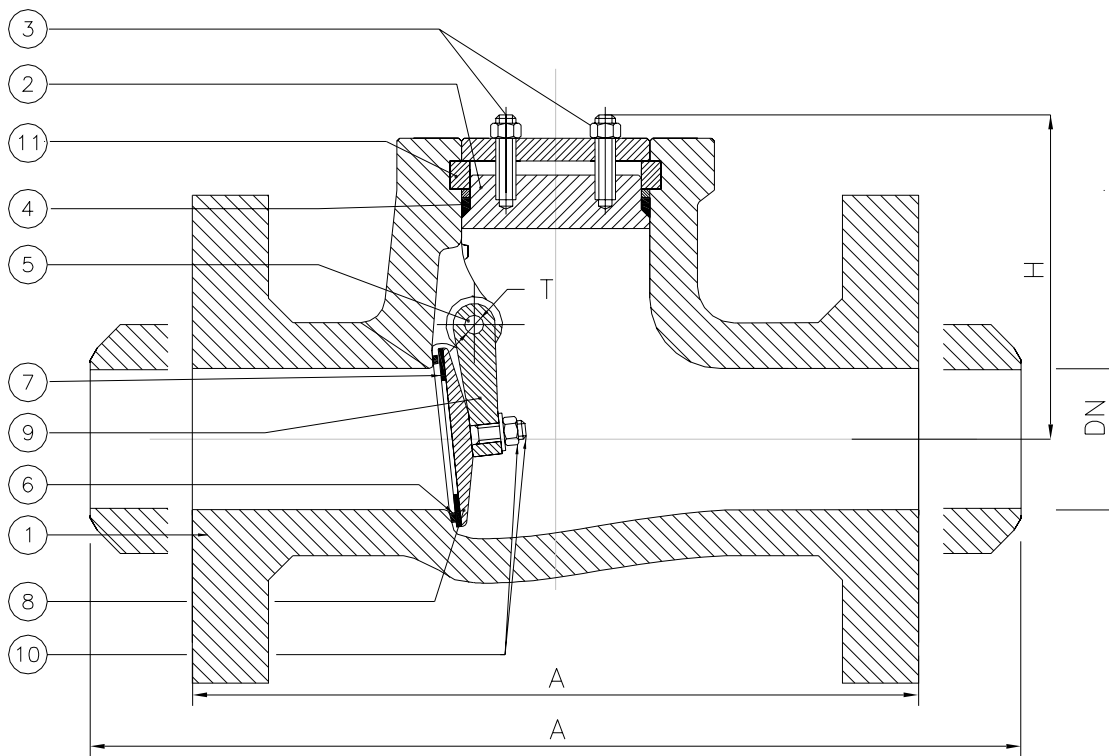

0948

Rel. 5.0

Standard features:

- Design EN 12516
EN 14341
- Face to face EN 558 series 91
DIN 3202 F9
- With flanges EN 1092-1/21/B2
- Materials EN 10213
EN 10269
EN 10088
- Bolts and nuts EN 1515-1
- Welding overlay AD-M HP 0
- Testing EN 12266
- Marking EN 19
- Certificates EN 10204

Optional versions:

- AD 2000 – A4
- TRD 110
- DIN 3230 Part 4
- DIN 3230 Part 5
- DIN 3230 Part 6
- TRbF 131
- TRbF 301 or 302
- ATEX
- TA-Luft
- With butt welding ends EN 12627
- With flanges form A, B1, B2, C, D, E, F, G, H
- With special devices (see page 52)

	DESCRIPTION	FIG. 297	FIG. 397	FIG. 397-J	FIG. 497	FIG. 497-H	FIG. 497-K
1	Body	1.0619	1.4581	1.4308	1.7357	1.7379	1.4931
2	Cover	1.0425 ⁽⁵⁾	1.4571	1.4301	1.7335	1.7380	1.4931
3	Bolts	1.7225 ⁽⁴⁾	1.4301 ⁽⁴⁾	1.4301 ⁽⁴⁾	1.7711 ⁽⁴⁾	1.7711 ⁽⁴⁾	1.7225 ⁽⁴⁾
3	Nuts	1.1191 ⁽⁴⁾	1.4301 ⁽⁴⁾	1.4301 ⁽⁴⁾	1.7225 ⁽⁴⁾	1.7225 ⁽⁴⁾	1.7225 ⁽⁴⁾
4	O Gasket	Graphite + SS ⁽³⁾	Graphite + SS ⁽³⁾	PTFE ⁽³⁾	Graphite + SS ⁽³⁾	Graphite + SS ⁽³⁾	Graphite + SS ⁽³⁾
5	X Hinge pin	1.4021 ⁽¹⁾	1.4571 ⁽¹⁾	1.4301 ⁽¹⁾	1.4021 ⁽¹⁾	1.4021 ⁽¹⁾	1.4923 ⁽¹⁾
6	Body seats	1.4502 ⁽²⁾	1.4581 ⁽²⁾	1.4308 ⁽²⁾	1.4502 ⁽²⁾	Stellite ⁽²⁾	Stellite ⁽²⁾
7	Disk seats	1.4502 ⁽²⁾	1.4430 ⁽²⁾	1.4301 ⁽²⁾	1.4502 ⁽²⁾	Stellite ⁽²⁾	Stellite ⁽²⁾
8	X Disk	1.0425 ⁽⁵⁾	1.4571	1.4301	1.7335	1.7380	1.4903
9	Hinge	1.0619	1.4581	1.4308	1.7357	1.7379	1.4903
10	Stud	1.7225 ⁽⁴⁾	1.4401 ⁽⁴⁾	1.4301 ⁽⁴⁾	1.7711 ⁽⁴⁾	1.7711 ⁽⁴⁾	1.7225 ⁽⁴⁾
10	Nut	1.1191 ⁽⁴⁾	1.4401 ⁽⁴⁾	1.4301 ⁽⁴⁾	1.7225 ⁽⁴⁾	1.7225 ⁽⁴⁾	1.7225 ⁽⁴⁾
11	Segmented ring	1.0425 ⁽⁵⁾	1.4571	1.4301	1.7335	1.7380	1.4903

⁽¹⁾ Also available on request 1.4571, 1.4301, 1.3964, Hastelloy, or other materials.

⁽²⁾ Also available on request stellite, 1.4462 (duplex), 1.4430, 1.4316, Hastelloy, or other materials.

⁽³⁾ Also available on request PTFE, Gore-tex, graphite, or other materials.

⁽⁴⁾ Also available on request 1.7225 / 1.1191, 1.7711 / 1.7225, 1.4401, 1.4301, A4-70 or other materials.

⁽⁵⁾ 1.0044 for swing check valves with DN over 125 mm.

O recommended spare parts for 2 years standard service; x recommended spare parts for 5 years standard service.

Dimensions

	DN	A	D	H	T	Kg
PN 320	50	350	210	190	10	65
	80	470	275	225	15	140
	100	550	335	300	15	240
	125	650	380	350	18	460
	150	750	425	370	18	540
	200	950	525	460	18	1150
	250	1150	640	560	24	1680
	300	1350	780	630	24	2240

Pressure Temperature Ratings (°C / bar)

	PN	-195	-150	-100	-50	-10	0	20	100	150	200	250	300	350	400	425	450	475	500	525	550	575	600
Fig. 297 ⁽⁶⁾	320					320	320	316	299	274	249	228	206	192	185	151	118						
Fig. 397 ⁽⁷⁾	320			320	320	320	320	309	263	245	228	217	206	196	185	181	178	174	171	167	164		
Fig. 397-J	320	320	320	320	320	320	320	302	228	203	178	167	156										
Fig. 497 ⁽⁸⁾	320					320	320	320	320	320	320	320	320	306	284	277	270	218	166	122	78		
Fig. 497-H ⁽⁸⁾	320					320	320	320	320	320	320	320	320	320	320	315	310	252	193	144	94	67	40
Fig. 497-K ⁽⁸⁾	320					320	320	320	320	320	320	320	320	320	320	320	320	307	294	231	168	119	70

Special ratings for butt welding ends versions only (desing pressure)

	PD	-195	-150	-100	-50	-10	0	20	100	150	200	250	300	350	400	425	450	475	500	525	550	575	600
Fig. 497-BW ⁽⁸⁾	448					448	448	448	448	402	356	341	327	306	284	277	270	218	166	122	78		
Fig. 497-H-BW ⁽⁸⁾	569					569	569	569	569	537	505	498	491	469	448	379	310	252	193	144	94	67	40
Fig. 497-K-BW ⁽⁸⁾	768					768	768	768	768	704	640	626	612	583	555	497	439	367	294	231	168	119	70

Please, in the inquiry and in the order, specify always the maximum service temperature when it's over 100 °C.

If the valves are provided with flanged connection PN 100 the maximum allowable pressure should be proportionally reduced.

⁽⁶⁾ Supplied suitable for service temperature up to 300°C and for higher temperatures only on request.

⁽⁷⁾ Suitable over 450 °C only if provided with stellite seats. ⁽⁸⁾ Suitable over 530 °C only if provided with 1.3964 pin.

General sale and delivery conditions and product guarantee as specified at pages 56 and 57.

Due to constant improvement all data and details contained in this catalogue are purely indicative and they can be subjected to change without notice.

Variants & Devices

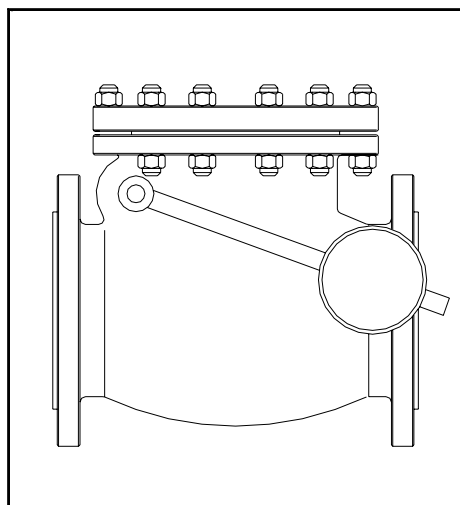

Var. 2010
Lever and counterweight

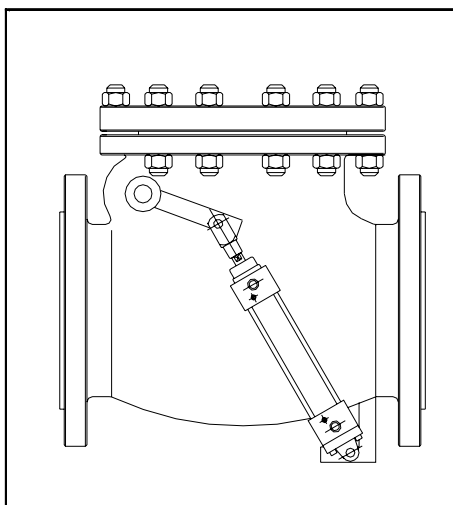

Var. 2020
Hydraulic linear brake

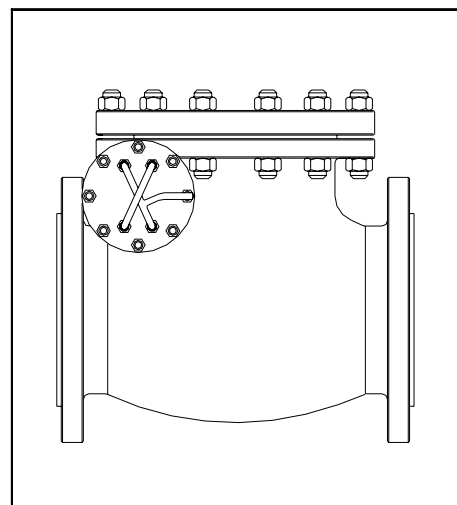

Var. 2030
Hydraulic rotative brake

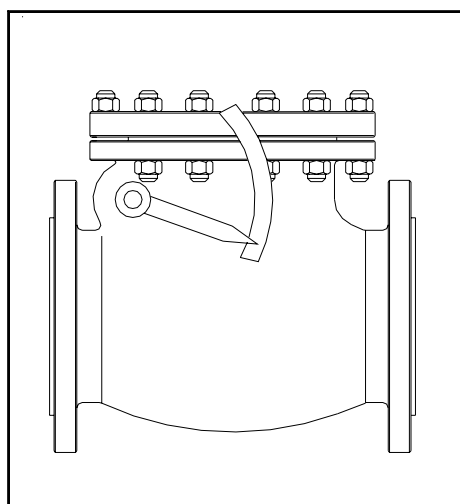

Var. 2110
Position indicator

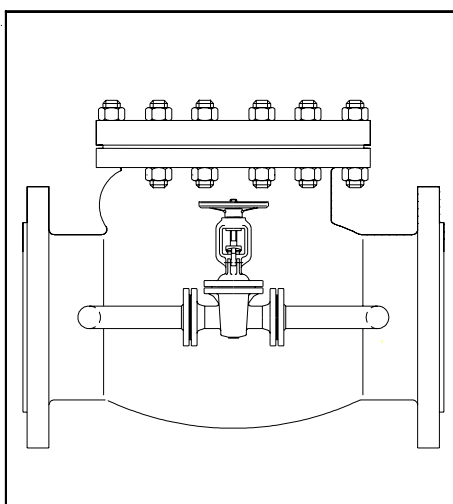

Var. 2300
By pass

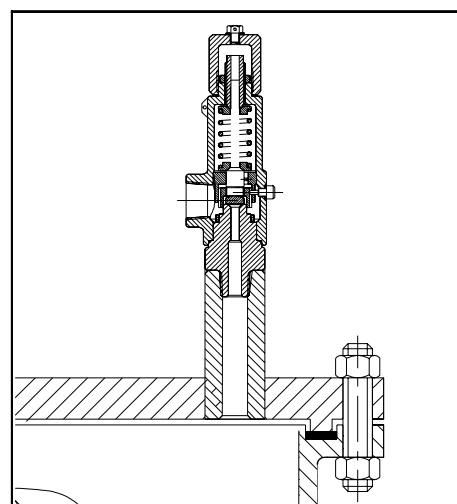

Var. 2400
Pressure relief valve

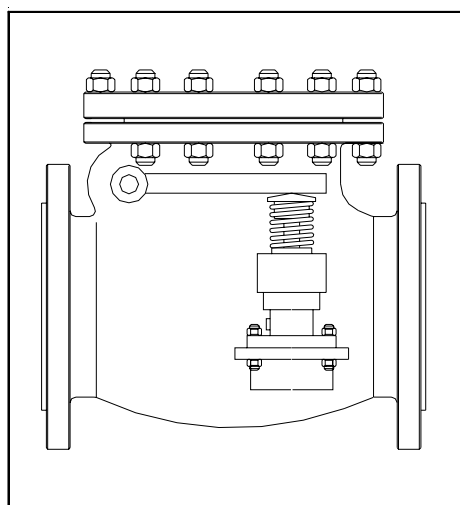

Var. 2500
Anti-shock device

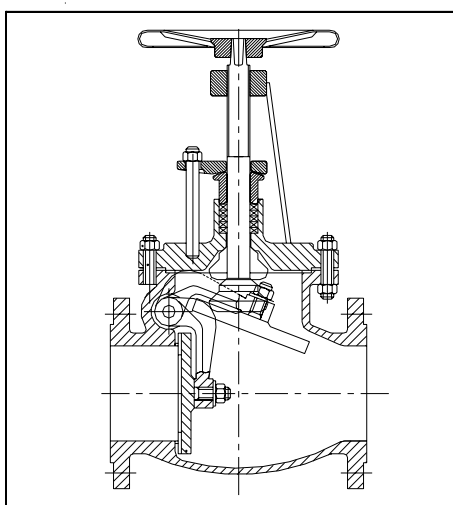

Var. 2600
Stop device

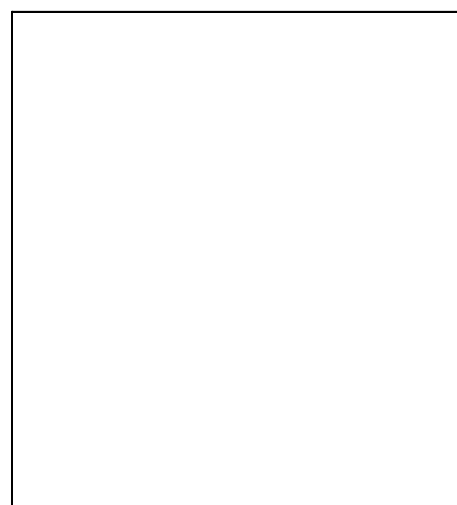

The drawings of the executions contained in this page are purely indicative, not binding and they can be subjected to change without notice.

Handling & Stocking

HANDLING

- 1) Don't lift the valves mean the handwheel or the operation device.
- 2) To lift the valve hook up them by the yoke or / and by the flange holes.
- 3) In all cases never drag the valve along the floor.
- 4) During the handling avoid damaging the coating with scratches.
- 5) If the valve is delivered on a pallet or in a crate don't remove it from the package and handle using an appropriate device (transpallet and / or cranes).

INSTALLATION & MAINTENANCE

- 1) Please refer always to the "Operating Instructions" supplied with the valves before to proceed with the installation.
- 2) For maintenance works follow strictly the "Operating Instructions" supplied with the valve and avoid absolutely improper operations: in case of doubt don't hesitate to contact RT's customer service and refer to the "Handbook" for more details.

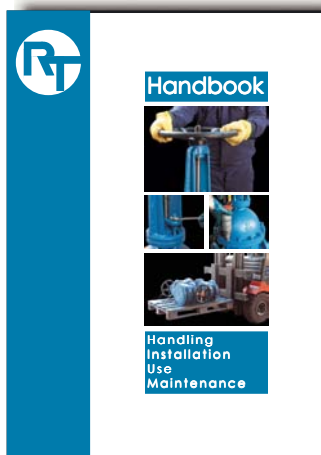

STOCKING

- 1) Stock the valves in an ambient with low humidity and protected from the wind.
- 2) Stock the valves in the original package and don't remove the original caps from the flanges.
- 3) Stock the valves in closed position.
- 4) Don't expose the valves to the sun, heat or rain.
- 5) If possible grease the stem and the yoke sleeve every 3 months.
- 6) In presence of sand or dust cover the valve, protect the stem and remove the plastic caps only in the moment of the installation.
- 7) After a stocking period of 18 months or more it's required to replace the gaskets and the stem packing before to install the valve.
- 8) If the valve is provided with an operation device (ex. electric actuator) don't remove the device protections until the installation.
- 9) Care the "Operating Instructions" for the valve and for the operation device (if present) with the valve until the moment of the effective installation.
- 10) The certificates, if enclosed in the packages under separate cover, should be removed and delivered to the Quality Assurance Department before to stock the valve.
- 11) If the valve is delivered in a crate for sea transport, after a period of 12 months it's required to open the package and to substitute the anti-humidity salts.
- 12) Remember always that improper stocking conditions can reduce the life of the valve and in some cases can cause also damages.

Safety Devices

When a gate valve during the service is closed, due to body - bonnet cavity, a part of the medium is trapped in a closed chamber (Fig. E1). If the medium is a liquid with high thermal expansion coefficient (ex. water) during the heating of the fluid the evaporation can rise the pressure in this chamber over the maximum admissible working pressure for the valve. This fact is very dangerous and can cause several damages to the body structure and to the gaskets. Further, the operation of the valve in this situation can be very difficult and sometime also impossible because the high pressure in the cavity block the wedge in the closed position.

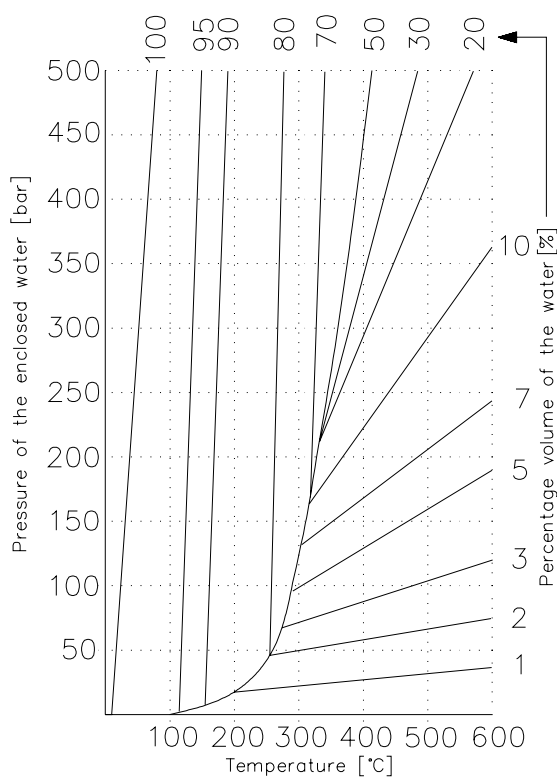

Fig. E2

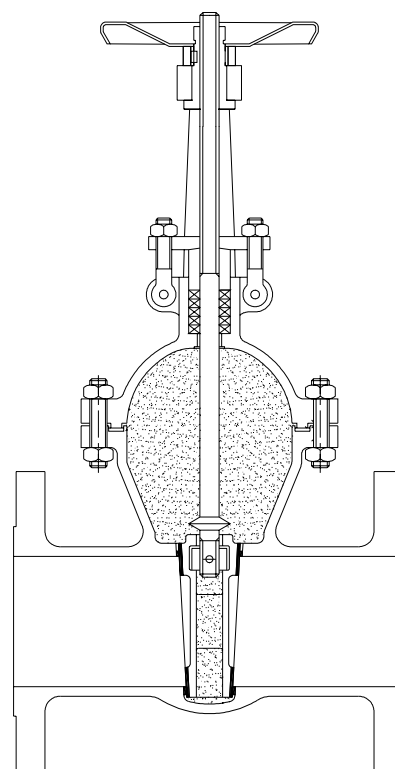

Fig. E1

This situation typically, but not only, can happen for valves used for steam and for liquid gases applications (cryogenic service).

The rise of the developing pressure is a function of the percentage of filling of the chamber with liquid and of the temperature (see the diagram in Fig. E2 valid for water). For a constant percentage of water a little increasing of the temperature cause a quick rise of the pressure in the closed chamber.

In such cases the gate valves shall be always provided with an appropriate safety device that equalise the pressure in the closed chamber.

Normally this safety device consists in two alternative solutions:

- 1) connecting the body - bonnet cavity with the upstream side with a hole in a side of the wedge (Fig. E3): in this way the overpressure is discharged directly in the system avoiding any external leakage, therefore in this way the valve can be used only for unidirectional service (because is guaranteed the full tightness in one direction only);
- 2) connecting the body - bonnet cavity with a small safety valve that can discharge the overpressure at the external but maintaining the valve tightness in both directions (Fig. E4); in this case the output side of the safety valve shall be appropriately connected with a discharge pipe to avoid any possible hazard for the people.

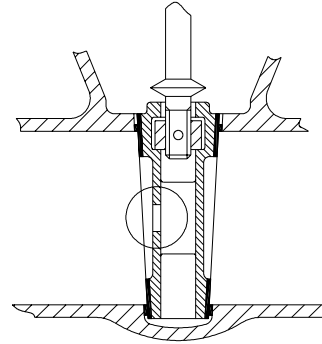

Fig. E3

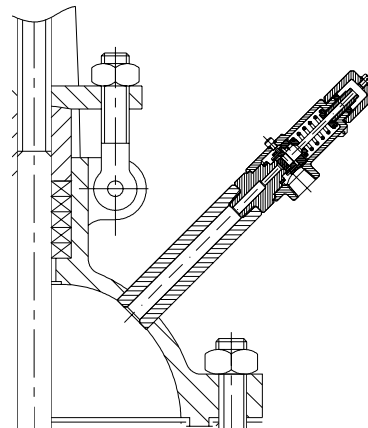

Fig. E4

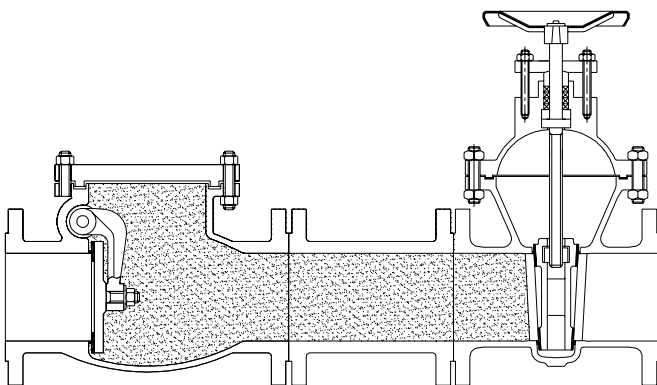

Fig. E5

The choice of the correct method is depending on the specific application. In such situations please contact always RT for a correct choice. The same problem can occur also with a swing check valve due to presence of a shut-off valve at the upstream side. In this case the closed cavity is formed by the pipe between the swing check valve and the shut - off valve (Fig. E5). In this situation the swing check valve or the pipeline shall be provided with a safety valve.

Sale & Delivery Conditions

- 1) The contract is closed only after the receipt by the Buyer of written order confirmation issued by RT Valvole Industriali according to the terms and conditions specified in the order confirmation.
- 2) If not differently agreed in the order confirmation the acceptance of order by R.T. Valvole Industriali Srl is subjected to the acceptance of the following conditions by the Buyer. Any other clause or condition specified in the inquiry or in the order by the Buyer have to be considered null and void and don't have any application also partial if not accept by written confirmation issued by RT Valvole Industriali Srl.
- 3) All the offered quantities are intended subject to prior sale and the delivery time stated in the offer or in the order confirmation, is to be intended from the order date and ex works Turbigo (according to Incoterm 2000).
- 4) The prices indicated in the price list and in the offers are not binding. R.T. Valvole Industriali Srl have the right to change the prices in any moment before the order confirmation without notice.
- 5) The information contained in the catalogue or in other commercial documents are not binding. R.T. Valvole Industriali Srl have the right to change in any moment all the material or construction details, which are not expressly specified in the order confirmation, without notice and without the Buyer approval.
- 6) RT Valvole Industriali Srl have the right to refuse the order in all the cases if the conditions stated in the order (prices, quantities, delivery or other details) make not economically profitable or convenient the supply and this right is valid for all the products also if listed in catalogue as available.
- 7) If not differently agreed in the order confirmation, the confirmed delivery time is not binding and in all cases it's admitted a tolerance of 30 days on the agreed delivery time. In case of delay over 30 days on the confirmed delivery time the Buyer will have the only right to cancel the order. The right to cancel the order is loss in case of materials ordered out of this catalogue or with special executions or special devices that make the product different from the standard version or for valves produced with body material different from 1.0619 or with nominal diameter (DN) over 300 mm or with nominal pressure (PN) over 63.
- 8) If not differently agreed in the order confirmation with a written acceptance signed by R.T. Valvole Industriali Srl, no compensation or penalty for the damages caused by a (partial or total) delayed delivery will be accepted.
- 9) In all the cases R.T. Valvole Industriali Srl can't be considered responsible for a delay caused by a delay in the supply of raw materials or components, or by an act of God.
- 10) If not differently agreed in the order confirmation the goods are always supplied "ex works" Turbigo according to INCOTERM 2000 packing excluded.
- 11) The goods, in all the cases, also if delivered free destination, travel on account and risk of the buyer.
- 12) If not differently stated in the catalogue or agreed in the order confirmation the "Technical conditions of delivery for valves" specified in the standards DIN 3230 part 1 and part 2 (current editions) are valid as formal contractual clauses.
- 13) All the valves ordered in the actuator predisposed version are supplied provided with connection flange according to ISO 5210 (if not differently specified) but without yoke sleeve or other necessary parts to assemble the actuator but not expressly requested in the order.
- 14) The certificates are supplied on request according to EN 10204 type 2.1. Other types (ex. 3.1, 3.2 etc.) will be delivered only if expressly required in the order with extra costs debited to Buyer as specified in the current price list. The certificates type 3.2 for the materials test can be supplied only if clearly and expressly requested by the Buyer in the order: the costs for the third party inspection, for materials, workmanship and use of testing devices necessary to issue these certificates will be completely on Buyer charge.
- 15) In case of inspection by the Buyer or a third party, and not differently agreed in the order confirmation, all the costs for the tests performed during the inspection and the necessary workmanship, will be debited to the Buyer. In all the cases the Buyer, or his authorised inspectors, will have the right to inspect the goods only if they will have advised R.T. Valvole Industriali Srl, about the visit, one week in advance at least. The execution, during the Buyer inspection, of supplementary tests or checks non originally specified in the order it's excluded.
- 16) All the quoted prices are with packing excluded. The cost of the packing will be invoiced to the Buyer according to current price list. If not differently agreed in the order confirmation the goods are packed in the most convenient way in the opinion of R.T. Valvole Industriali Srl.
- 17) If not differently agreed in the order confirmation the valves will be provided with external raw surfaces sandblasted. The necessary production weldings are grinded and not necessarily sandblasted. The valves in carbon or low alloyed steels are painted with a coating suitable to protect the valves against the rust up to the installation and in all cases for a period not longer than 12 months. No other surface treatment or coating will be provided if not differently specified in the order confirmation.
- 18) Orders with amount less than 1000 EURO will be charged for bookkeeping costs according to the current price list.
- 19) All the products are guaranteed against production defects according to the terms specified in the guarantee terms enclosed in the catalogue.
- 20) In all the cases R.T. Valvole Industriali Srl is not responsible for the quality, the suitability and the integrity of the products supplied by the Buyer to complete an order.
- 21) The certificates, if required, are delivered in single copy with the goods or by separate cover sent by mail.
- 22) The invoices will be delivered in single copy with the goods or by separate cover sent by mail.
- 23) If not differently agreed in the order confirmation all the goods will be invoiced in EURO currency.
- 24) If not differently agreed in the order confirmation or in the invoice, the payment term is 30 days from the invoice date.
- 25) In case of delayed payment R.T. Valvole Industriali Srl will be authorised to debit the Buyer the interest calculated on the total amount of the supply. The minimum interest rate applied will be equal to the statutory rate established by the European Directive 2000/35/EC Art. 3, subject to major damages.
- 26) For all goods and services supplied by RT Valvole Industriali is valid the retention title as established by the European Directive 2000/35/EC Art. 4, this means that the goods until the complete payment of the due amount will remain exclusive propriety of RT Valvole Industriali Srl.
- 27) For all the litigation or dispute about the sale and delivery conditions it is valid the Italian law only.
- 28) For all the litigation or dispute about the sale and delivery conditions it is competent the court of Milan.

Product Guarantee

Guarantee

By this Guarantee, RT Valvole Industriali Srl guarantees his products to be free of visible defects on materials and workmanship at the time of its original purchase for the period of 12 months from the installation or 18 months from the purchase from RT Valvole Industriali Srl. If during this period of guarantee the product proves defective due to improper workmanship or material defects, RT Valvole Industriali Srl will, without charge the Buyer for labour and spare parts, repair or (at the discretion of RT Valvole Industriali Srl) replace this product or its defective parts or reimburse the Buyer the amount invoiced on the conditions explained hereafter. On RT Valvole Industriali Srl request the Buyer is obliged to send back the product supposed defective FCA Turbigo, Italia (according INCOTERM 2000) as completely drained and vented from service fluid (if the retuned product is not completely drained and vented from service fluid RT Valvole Industriali Srl have the right refuse the guarantee service). The request by RT Valvole Industriali Srl to return back the product supposed defective can't be considered in any case as an acknowledgement of defect existence. In case of product effectively defective and sold FCA or FOB (according to INCOTERM 2000) RT Valvole Industriali Srl will reimburse the Buyer for the transport costs from the original destination to Turbigo works and will provide directly the transport by return to the original destination.

Producer responsibility limitation

This guarantee is the only responsibility for products defects or not conformities. For this reason they are excluded all other conventional or legal, implicit or explicit responsibilities. After the expiration of this guarantee the Buyer will cannot make any other request for reimbursement or compensation or price reduction or contract resolution or remedy. Except fraud or gross negligence by RT Valvole Industriali Srl, the compensation for all damages occurred to the Buyer can't be greater than the total value of the defective and / or not conform products.

Responsibility for putting in circulation the products

All responsibilities that can arise for the putting in circulation the products, enclosed therein possible damages to people and / or things will be on exclusive charge of the Buyer that get mixed up to discharge RT Valvole Industriali Srl from all possible requests from third party. The Buyer, moreover, get mixed up also to assure in a proper way against all risks coming from the use and the ownership of the products, without recourse right against RT Valvole Industriali Srl.

Conditions

- 1) The guarantee will be granted only if the claim is explained sending a copy of this guarantee with the complete data of the Buyer and of the defective product. RT Valvole Industriali Srl reserves the right to refuse guarantee service if the mark RT or the heat number or the size or the pressure rating or the CE tag plate have been removed from the valve or modified.
- 2) A valve will be never considered defective in materials or workmanship if it need to be adapted, changed or adjusted to conform it to the national or local technical or safety standards in force in any country which are different than EN ones. This guarantee shall not reimburse (a) such adaptations, changes, or adjustments or attempts to do so, whether properly performed or not, nor (b) any damage resulting from them.
- 3) This guarantee covers none of the following:
 - A) periodic check-up, maintenance, and repair or replacement of parts due to normal wear and tear;
 - B) the risks of transport relating directly or indirectly to the guarantee of these products;
 - C) damages to these products resulting from:
 - i) abuse and misuse, included but not limited to (a) the use of the products outside of the limits specified in the CE tag plate or outside of the material temperature / pressure ratings, or (b) the use the products outside of their normal purposes (as specified in the order or order confirmation according to DIN 3230 part 1 and part 2 standards or, if not detailed in these ones, for pure water at 20°C at speed of 1 m/sec and pressure equal to nominal pressure for sectionalising service) or, (c) the use of the products contrarily to RT Valvole Industriali Srl instructions on the proper use and maintenance, (d) the installation or the use of the products in a manner inconsistent with the technical or safety regulations in force in the country were these products are used or inconsistent with EN standards and RT Valvole Industriali Srl instructions;
 - ii) repair done by other than RT Valvole Industriali Srl;
 - iii) accident, acts of God, or any cause beyond the control of RT Valvole Industriali Srl, including but not limited to lightning, water, fire, and public disturbances;
 - iv) improper storing conditions care of the Buyer or other than RT Valvole Industriali Srl;
 - D) hidden defects in the materials not detectable with the standard tests and checks required by the European Directive 97/23/EC and with the tests and checks required in the order.
- 4) The durability of all parts subjected to wear or natural ageing as (but not only) gaskets, packings, roll bearings, yoke sleeves and coating is not covered by this guarantee.
- 5) If not differently confirmed by RT Valvole Industriali Srl with written acceptance the correct functioning of the valve is not guaranteed in these situations:
 - a) free discharge service or in all cases for service different from simple sectionalising service
 - b) installation in different positions than those specified as allowable in the installation use and maintenance manual
 - c) use outside of the limits specified in the CE tag plate or for service in class IV according to Directive 97/23/EC
 - d) use for corrosive or toxic or dangerous fluids for which they have not been specified in the inquiry and in the order the temperature and the chemical composition.
- 6) If not differently agreed in the order confirmation, the final coating suitable for the specific application is on Buyer responsibility and it shall be applied for a correct protection against the corrosion before the use. The standard painting applied by RT Valvole Industriali Srl is intended to protect the valves during the transport and the stocking periods during maximum 12 months from the delivery, and no guarantee is given for the suitability and the durability of this painting for the specific operating conditions (temperature, humidity, etc). In all the cases, also if the coating is provided according to Buyer specifications, it have to be considered as part subject to wear and for this reason his durability is not covered by this guarantee.
- 7) The Buyer right of exercise this guarantee is loosed if the products are manumitted or repaired or modified by other than RT Valvole Industriali Srl.
- 8) In all the cases the compensation for the expenses to repair a defective product is excluded.
- 9) In all the cases the compensation of direct or indirect damage of any nature at things or people for the use or the use interruption of RT Valvole Industriali Srl products is excluded.
- 10) For all litigations or disputes about the terms or the conditions or the exercise of the guarantee is valid only the Italian law.
- 11) For all litigations or disputes about the terms or the conditions or the exercise of the guarantee it's competent the court of Milan.

Standard Comparison

Steel No. (EN)	EN (DIN - UNI - BS - AFNOR)	AISI - SAE - ASTM	AFNOR (old name)	BS (old name)	JIS	GOST
1.0044	S275JR	A 570 Gr 40 / A 36	E 28-2	Fe 430 B	SM 400 B	St4ps
1.0352	P245GH	A 105 N	XC18	-	-	-
1.0402	C22	M 1023	AF42C20	055 M 15	S 20 C	20
1.0425	P265GH	A 515 Gr 60	A42-CP	1501-161 400	SB 410	-
1.0460	C22.8	-	-	-	-	-
1.0478	P285QH	A350 LF2	A42CP	1501 Gr 161-400	SPV315	16K
1.0486	P275N	A 106 / A 234 WPB	-	-	SM 400 A	-
1.0487	P275NH	A 516 Gr 60	-	224 - 400 A	-	-
1.0488	P275NL1	A516 Gr 60	A42AP	1501-224 400	SGV 410	-
1.0511	C40	1040	1 C 40	080 M 40	-	-
10562	P355N	A 350 LF1 / A 516 Gr70	A 510 AP	225 - 490 A	SM 490 A	-
1.0565	P355NH	A 516 Gr 70	A510 AP	225 - 490 A	-	-
1.0566	P355NL1	A 516 Gr 70	A510 FP	225 - 490 A	STK 490	-
1.0619	GP240GHN	A 216 WCB	A480CP-M	1504-161 Gr B	-	-
1.1104	P275NL2	-	A 510 AP	224 - 400 A	STK 400	-
1.1106	P355NL2	-	-	225 - 490 A	STK 490	-
1.1131	G17Mn5	-	-	-	-	-
1.1138	GS21Mn5	A 352 LCC	-	-	-	-
1.1156	GSCK24	A 352 LCB	-	-	-	-
1.1181	C35E	-	-	-	-	-
1.1191	C45E	A 194 2H	AF65C45	162	-	-
1.3964	X2CrNiMnMoNb21-16-5-3	A479 XM-19	-	-	-	-
1.4021	X20Cr13	A 420	Z20C13	420 S 37	SUS420J1	20Ch13
1.4107	GX8CrNi12	-	-	-	-	-
1.4301	X5CrNi18-9	A 304 / B8	Z7CN18-09	304S31	SUS304	08Ch18N10
1.4305	X12CrNi18-8	A 303	Z8CNF18-09	303S31	SUS303	-
1.4306	X2CrNi19-11	A 304L	Z1CN19-11	304S11	SUS304L	03Ch18N11
1.4308	GX5CrNi18-9	A 351 CF8	Z6CN18-10M	304C15	SCS13	07Ch18N9L
1.4309	GX2CrNi19-11	A 351 CF3	Z3CN19-9M	-	-	-
1.4311	X2CrNi18-10	A 304 LN	Z3CN18-10Az	304S61	SUS 304LN	-
1.4317	GX4CrNi13-4	A 352 CA6NM	-	425 C11	-	-
1.4362	X2CrNi23-4	S32304 (2304)	Z2CN23-04AZ	-	-	-
1.4401	X5CrNiMo17-12-2	A 316 / B8M	Z7CND17-11-02	316S31	SUS316	-
1.4404	X2CrNiMo17-13-2	A 316L	Z3CND17-11-02	316S11	SUS316L	-
1.4405	GX4CrBiMo16-5	-	-	-	-	-
1.4408	GX5CrNiMo19-11-2	A 351 CF8M	-	316 C 16	SCS 14	07Ch18N10G2S2M2L
1.4409	GX2CrNiMo19-11-2	A 351 CF3M	Z2CND18-12-3M	-	-	-
1.4410	X2CrNiMoN25-7-4	A 182 F53 (2507)	Z5CND20.10M	-	SCS 14A	-
1.4430	X2CrNiMo19-12	AWS A5.9 ER 316L	Z2CND20.10	316S92	-	-
1.4458	GX2NiCrMo28-20-2	-	-	-	-	-
1.4462	X2CrNiMoN22-5-3	A 182 F51 (2205)	Z3 CND 25-06-3	318 S13	-	-
1.4469	GX2CrNiMo26-7-4	A890 Gr 5A (2507)	-	-	-	-
1.4470	GX2CrNiMoN22-5-3	A890 Gr 4A (2205)	-	-	-	-
1.4500	GX7NiCrMoCuNb25-20	Uranus B6M	Z3CNUD25-20M	-	-	-
1.4502	X8CrTi18	AWS A5.9 ER 430	Z8CT17	-	-	-
1.4517	GX3CrNiMoCuN25-6-3-3	A890 Gr 1A	-	-	-	-
1.4529	X1CrMoCuN25-20-6	A744CK3MOUN(254SMO)	-	-	-	-
1.4539	X1NiCrMoCu25-20-5	UNS N08 904 L	Z1NCUD25-20	-	SUS329J3L	-
1.4541	X6CrNiTi18-10	A 321	Z6CNT18-10	321S31	SUS321	06Ch18N10T

All the correspondence here indicated are purely indicative. They can be used only as guideline in the choice of different material. In all the cases RT valves will not be responsible for any choice based on these data.

Steel No. (EN)	EN (DIN - UNI - BS - AFNOR)	AISI – SAE - ASTM	AFNOR (old name)	BS (old name)	JIS	GOST
1.4550	X6CrNiNb18-10	A 347	A6CNNb18-10	347S31	SUS347	-
1.4552	GX5CrNiNb19-11	A 351 CF8C	Z6CNNb18-10M	347C17	SCS21	-
1.4563	X1NiCrMoCu31-27-4	Sanicro 28	-	-	-	-
1.4571	X6CrNiMoTi17-12-2	A 316Ti	Z6CNDT17-12	320S17	-	10Ch17N13M2T
1.4580	X6CrNiMoNb17-12-2	A 316Cb	Z6CNDNb18-12	318S17	-	-
1.4581	GX5CrNiMoNb19-11-2	-	Z4CNDNb18-12M	318C17	SCS 22	OTA 10NbMoNiCr170
1.4903	X10CrMoVNb9-1	A 182F91	-	-	-	-
1.4931	GX23CrMoV12-1	-	-	-	-	-
1.5415	16Mo3	A 204 Gr A	15 D 3	-	-	-
1.5419	G20Mo5	A 217 WC1	-	-	-	-
1.5422	G18Mo5	-	-	-	-	-
1.5636	G9Ni10	-	-	-	-	-
1.5637	12Ni14	A 203 Gr D / A350 LF3	12 N 14	503	SL3N255	-
1.5638	G10Ni14	A 352 LC3	-	-	-	-
1.5662	X8Ni9	A 333 Gr 8 / A533 Gr1	9 Ni	502 - 650	SL9N520	-
1.5680	X12Ni5	A 2515 / A 645	5 Ni	-	SL5N590	-
1.6220	G20Mn5	A 352 LCC	-	-	-	-
1.6228	15NiMn6	-	15 N 6	-	-	-
1.6781	G17NiCrMo13-6	-	-	-	-	-
1.6982	GX3CrNi13-4	-	-	-	-	-
1.7219	26CrMo4	-	-	-	-	-
1.7225	42CrMo4	A 193 B7 / L7 / 7 / 4	42CD4	-	-	-
1.7258	24CrMo5	-	-	-	-	-
1.7219	G26CrMo4	A 352 LC1	FC1-M	-	-	-
1.7335	13CrMo4-5	A182 F11	15CD4-05	620-470	SFVA F 12	15ChM
1.7353	G12CrMo19-5	A217 C5	Z13CD5	-	-	-
1.7357	G17CrMo5-5	A 217 WC6	15CD4-05-M	-	-	-
1.7362	12CrMo19-5	A182 F5	-	-	-	-
1.7365	GX15CrMo5	-	-	625	-	-
1.7379	G19CrMo9-10	A 217 WC9	-	-	-	-
1.7380	10CrMo9-10	A182 F22	12 CD 9.10	1501-622	SFVA F22 A	12Ch8
1.7383	11CrMo9-10	A182 F22	15 CD 4.05	-	-	-
1.7389	G-X12CrMo10-1	A217 C12	-	B6	-	-
1.7706	G17CrMoV5-10	A 356 Gr 9	-	-	SPCH 23	-
1.7709	21CrMoV5-7	-	-	-	-	-
1.7711	40CrMoV4-6	A 193 B16	42CDV4	670-860	-	-
1.7720	G12MoCrV5-2	-	-	-	-	-
2.4066	Ni 99.2	CZ100 (Nickel 200)	-	-	-	-
2.4360	NiCu30Fe	M-35-1 (Monel 400)	-	-	-	-
2.4537	NiMo16CrW	CW-12M (Hastelloy C)	-	-	-	-
2.4602	NiCr21Mo14W	Hastelloy C22	-	-	-	-
2.4617	NiMo28	Hastelloy B2	-	-	-	-
2.4810	NiMo30	N-7M (Hastelloy B)	-	-	-	-
2.4816	NiCr15Fe	CY40 (Inconel 600)	-	-	-	-
2.4819	NiMo16Cr15W	Hastelloy C276	-	-	-	-
2.4856	NiCr22Mo9Nb	CW6MC (Inconel 625)	-	-	-	-
2.4858	NiCr21Mo	Incolloy 825	-	-	-	-

All the correspondence here indicated are purely indicative. They can be used only as guideline in the choice of different material. In all the cases RT valves will not be responsible for any choice based on these data.

Photo Gallery

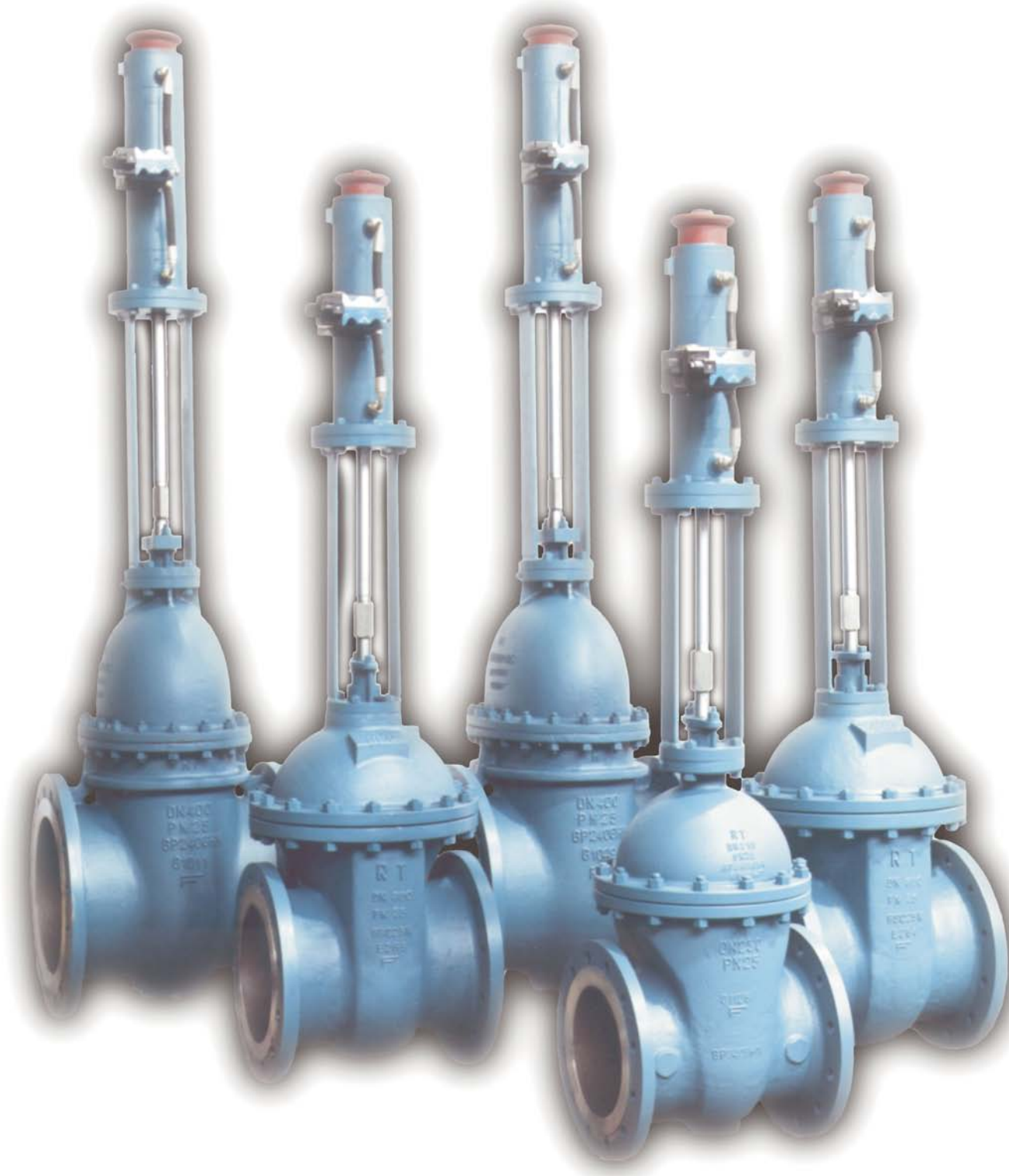

Gate valves with hydraulic actuator (Fig. 240 Var. 1520 -H)

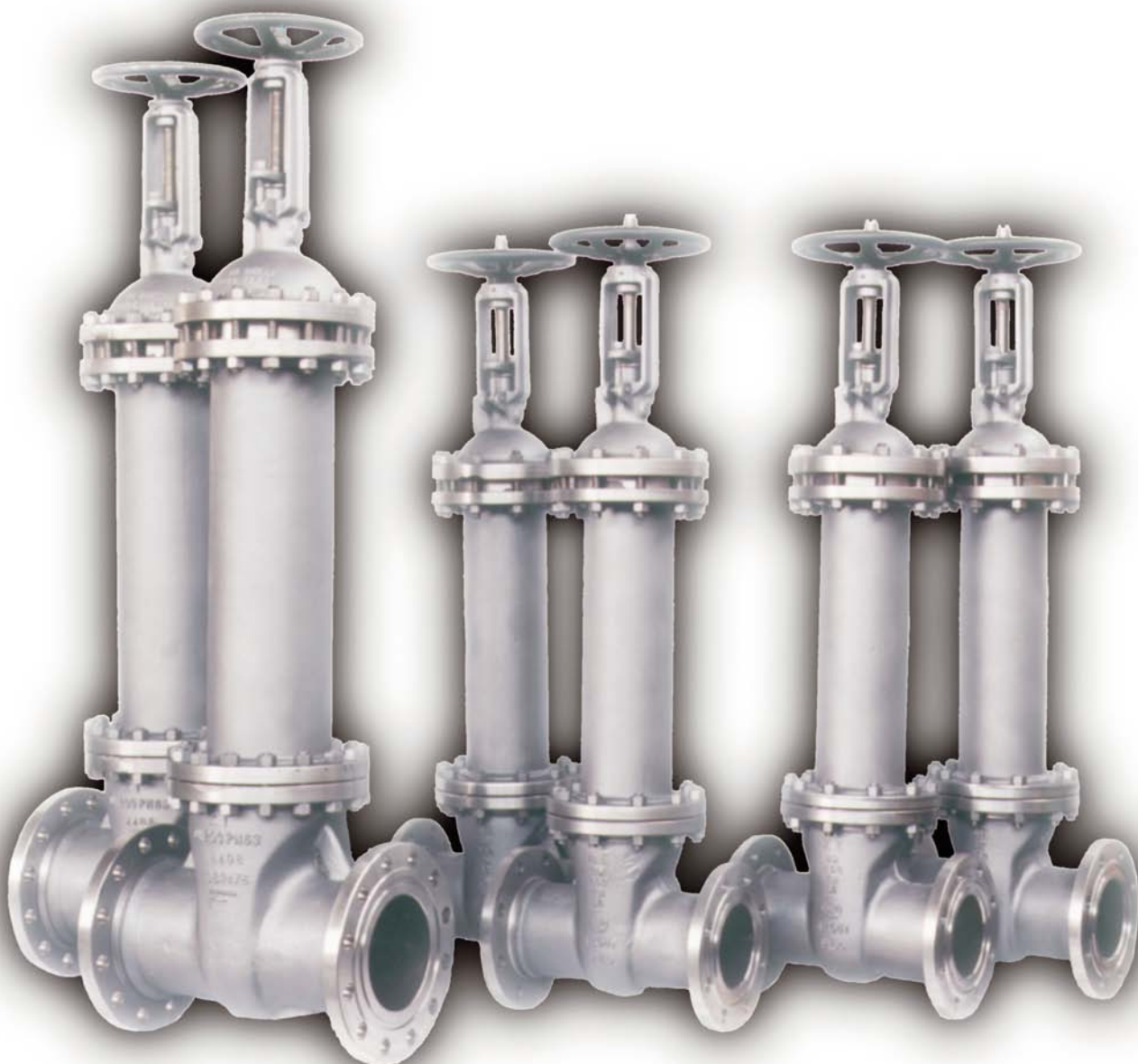

Stainless steel gate valves with bellow seal (Fig. 350 Var. 1070)

Photo Gallery



Gate valve DN 900 PN 25 (Fig. 240 Var 1530) and gate valve DN 50 PN 25 (Fig. 240)

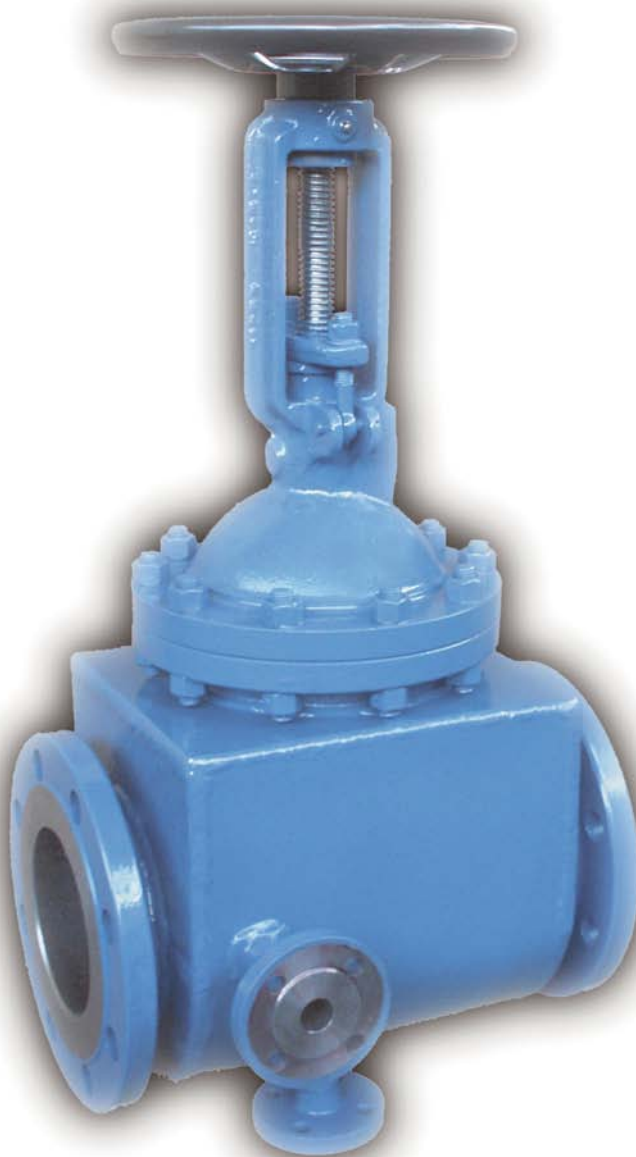

Gate valve with steam jacket (Fig. 250 Var. 1080)

Photo Gallery

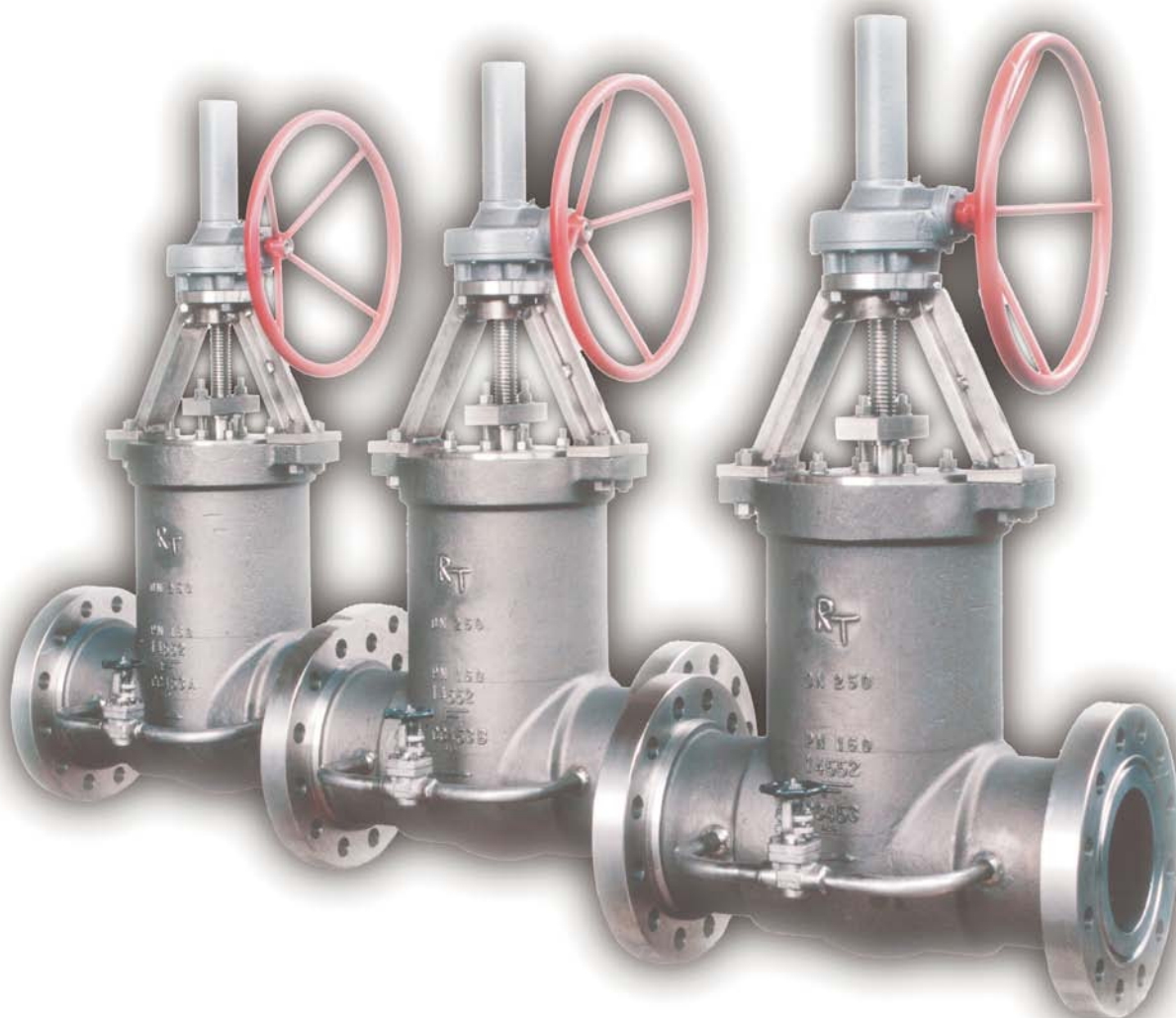

Stainless steel gate valves DN 250 PN 160 pressure seal desing (Fig. 361 Var.1510)



Swing check valve DN 700 PN 25 with lever and weight (Fig. 270 Var. 2010)

Photo Gallery



Steel gate valves DN 150 PN 250 pressure seal desing (Fig. 266 Var.1510)



Swing check valve DN 200 PN 25 with hydraulic rotative brake (Fig. 270 Var. 2030)



RT valvole Industriali Srl
Via Alle Cave 25 / 29
20029 Turbigo (MI)
ITALY

Phone: +39 0331 891060
Fax: +39 0331 891068

URL: <http://www.rtvales.com>
e-mail: info@rtvalves.com

