

Control valve - straight through with flanges and shaft guided plug
1" to 8" (DN 25 - 200)

ARI-STEVI® 470 / 471 - ANSI

Electric actuator ARI-PREMIO

- Enclosure IP 65
- 2 torque switches
- Handwheel
- Additional devices available, e.g. potentiometer

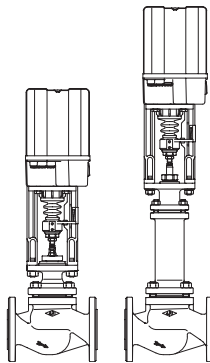

Page 2

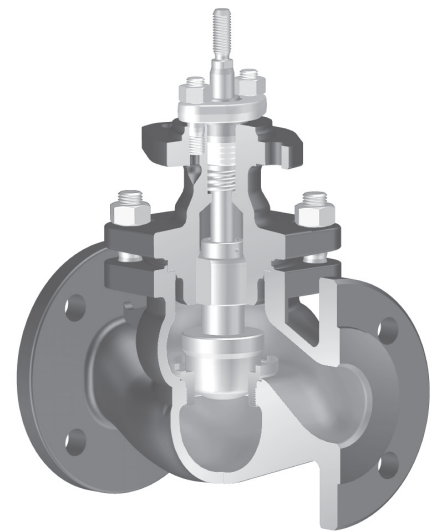
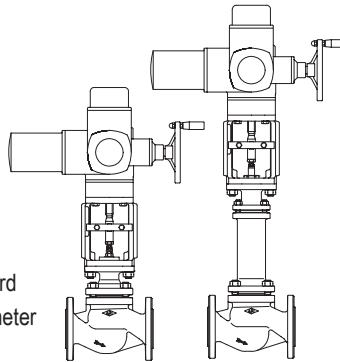

Fig. 470 - ANSI

ARI-STEVI® 470 / 471 - ANSI

Electric actuator AUMA SAR

- Electric multiturn actuator, capable of high closing pressures
- Enclosure IP 67
- 2 torque switches
- 2 travel switches
- Handwheel
- Overheating protection for motor as standard
- Additional devices available, e.g. potentiometer
- Explosion proof version available



Page 6

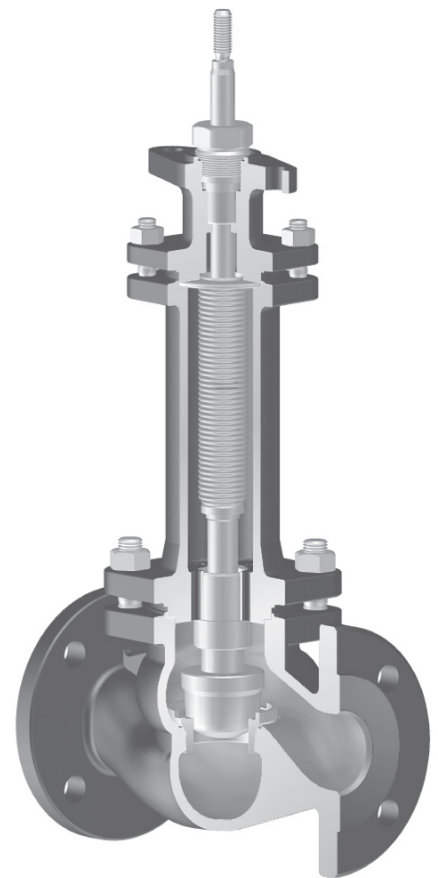
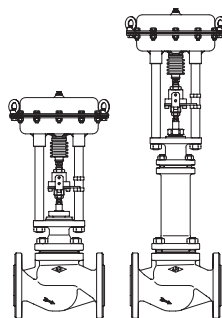

Fig. 471 - ANSI

ARI-STEVI® 470 / 471 - ANSI

Pneumatic actuator ARI-DP

- Reversible pneumatic actuator
- Actuator with rolling diaphragm
- Air supply pressure max. 87 psi / 6 bar
- Stem protection by bellow
- Maintenance-free O-ring sealing
- Assembly of additional devices acc. to DIN IEC 60534-6



Page 10

Features:

- Compact design
- Precision guided stem
- Burnished stem
- Tapered seat ring
- Replaceable seal and plug
- Screwed seat ring
- Cv- / Kvs-values reducible up to 6 times
- Rangeability
50 : 1 (1"-6" / DN25-150)
30 : 1 (8" / DN200)
- Post guided plug
- Spring loaded PTFE-V ring packing unit
- Two-ply bellows seal as standard
- Travel indicator

Control valve in straightway form with electric actuator ARI-PREMIO

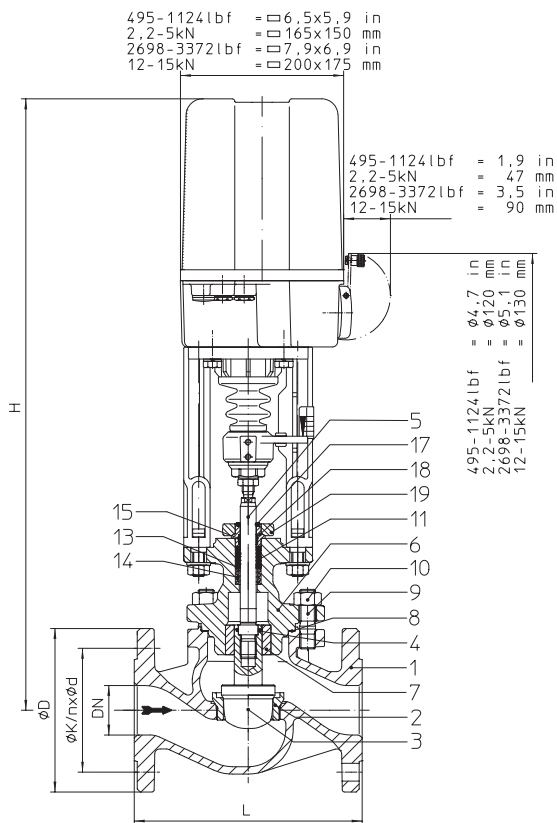

Fig. 470 - ANSI

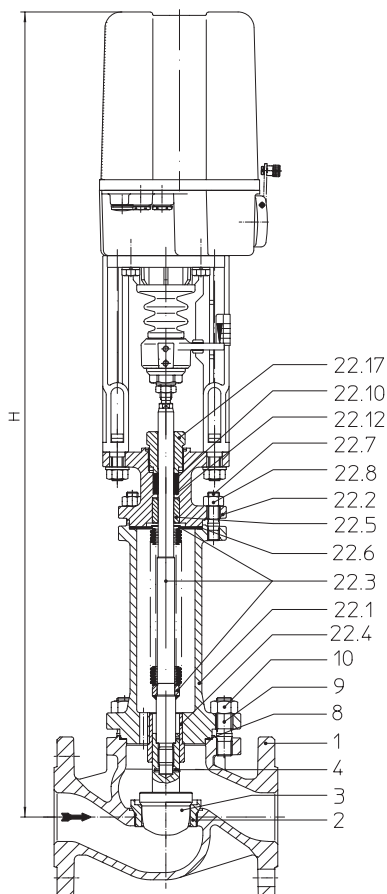

Fig. 471 - ANSI

Figure	Nominal pressure	Material	Nominal diameter
35.470...90 / 35.471...90	ANSI 300	SA 216 WCB	1" - 8" / DN 25-200
Other materials and versions on request.			
Stem sealing			
Fig. 470: <ul style="list-style-type: none"> • PTFE-V-ring unit (to 6" / DN150) +14°F to +428°F / -10°C to +220°C • PTFE-packing +14°F up to +482°F / -10°C up to +250°C • Pure graphite-packing +14°F up to +842°F / -10°C up to +450°C 			
Fig. 471: <ul style="list-style-type: none"> • Stainless steel bellows seal (for restricted pressure range) -76°F up to +842°F / -60°C up to +450°C 			
Plug design standard:			
<ul style="list-style-type: none"> • Parabolic plug, metal seat (1"-6" / DN25-150) • V-port plug, metal seat (8" / DN200) 			
optional:			
<ul style="list-style-type: none"> • Parabolic plug with PTFE soft seat (max. 392°F / 200°C) (1"-6" / DN25-150) • V-port plug, metal seat (from seat-ø 2,56 in / 65 mm) • Perforated plug, metal seat • Parabolic pressure balanced plug (or perforated plug), metal seat; 			
Material of piston seal: PTFE with stainless steel spring (max. 392°F / 200°C)			
Guiding			
<ul style="list-style-type: none"> • Parabolic plug: post guiding • Perforated / V-port plug: post and port guiding 			
Flow characteristic			
<ul style="list-style-type: none"> • Equal percentage or linear (from Kvs 100 modified equal percentage, Miniature-Kvs-values ≤ 0,63 only equal percentage)			
Rangeability			
<ul style="list-style-type: none"> • 50 : 1 on parabolic plug • 30 : 1 on perforated plug / V-port plug 			
Shut off class (seat / plug leakage classes)			
<ul style="list-style-type: none"> • Metal seat - Leakage class IV acc. to ANSI / FCI 70-2 • Soft seat - Leakage class VI acc. to ANSI / FCI 70-2 (from Cv 1,2 / Kvs 1,0) 			
Closing pressures refer to page 4.			
Technical data for actuator refer to data sheet.			

Selection of possible applications

Industrial installations, processing technology, plant manufacturing, etc. (other applications on request)

Selection of possible flow media

Fig. 470-ANSI: Cooling water, cooling brine, warm water, hot water, steam, gas, etc.

Fig. 471-ANSI: Refrigerant, cooling water, warm water, hot water, thermal oil, steam, gas, etc. (other flow media on request)

Dimensions and weights

Nominal diameter		1"	1 1/2"	2"	3"	4"	6"	8"	
L	(in)	7,75	9,25	10,5	12,5	14,5	18,62	22,38	
Fig. 470	H	(in)	23,1	24,3	24,3	25,5	25,6	28,8	31,1
	ARI-PREMIO 495 lbf	(lb)	35,1	52,7	57,1	101,2	157	292	--
	ARI-PREMIO 1124 lbf	(lb)	37,5	55,1	59,5	103,6	160	294	497
	H	(in)	--	30,2	30,2	31,4	31,5	34,6	37,5
	ARI-PREMIO 2698 lbf	(lb)	--	63,9	68,4	112,5	169	303	506
	ARI-PREMIO 3372 lbf	(lb)	--	63,9	68,4	112,5	169	303	506
Fig. 471	H	(in)	29,3	32,6	32,6	33,3	34,5	41,7	50
	ARI-PREMIO 495 lbf	(lb)	41,2	62	66,4	114,4	165	310	--
	ARI-PREMIO 1124 lbf	(lb)	43,7	64,4	68,8	116,9	167	312	522
	H	(in)	--	38,5	38,5	39,3	40,4	47,5	56,4
	ARI-PREMIO 2698 lbf	(lb)	--	73,2	77,6	125,7	176	321	530
	ARI-PREMIO 3372 lbf	(lb)	--	73,2	77,6	125,7	176	321	530
Nominal diameter		DN 25	DN 40	DN 50	DN 80	DN100	DN150	DN200	
L	(mm)	197	235	267	318	368	473	568	
Fig. 470	H	(mm)	587	618	618	647	649	731	790
	ARI-PREMIO 2,2 kN	(kg)	15,9	23,9	25,9	45,9	71	132	--
	ARI-PREMIO 5 kN	(kg)	17	25	27	47	73	134	230
	H	(mm)	--	768	768	797	799	879	953
	ARI-PREMIO 12 kN	(kg)	--	29	31	51	77	138	230
	ARI-PREMIO 15 kN	(kg)	--	29	31	51	77	138	230
Fig. 471	H	(mm)	744	829	829	847	877	1058	1271
	ARI-PREMIO 2,2 kN	(kg)	18,7	28,1	30,1	51,9	75	140	--
	ARI-PREMIO 5 kN	(kg)	19,8	29,2	31,2	53	76	142	237
	H	(mm)	--	979	979	997	1027	1206	1434
	ARI-PREMIO 12 kN	(kg)	--	33,2	35,2	57	80	146	241
	ARI-PREMIO 15 kN	(kg)	--	33,2	35,2	57	80	146	241

Standard-flange dimensions refer to page 23.

Face to face dimension Form RF acc. to ANSI / ISA-S75.03 - 1992 (Face to face dimensions for flanges Form RTJ on request.)

Parts

Pos.	Description	Fig. 35.470...90 / Fig. 35.471...90
1	Body	SA 216 WCB
2	Seat ring *	SA 276 Gr.420
3	Plug *	SA 276 Gr.420
4	Straight spin *	A2
5	Stem *	SA 276 Gr.420
6	Mounting bonnet	SA 216 WCB
7	Guide bushing	SA 276 Gr.420 (hardened)
8	Gasket *	Pure graphite (CrNi laminated with graphite)
9	Studs	SA 193 B7
10	Hexagon nuts	SA 194 2H
11	V-ring unit *	PTFE
13	Washer *	SA 240 Gr. 304
14	Spring *	AISI 301 A313 Gr.301
15	Strip *	PTFE25%C
17	Scraper *	PTFE
18	Stem guiding *	AISI 303
19	Packing box flange	SA 105
20	Studs (refer to page 24)	A4-70
21	Hexagon nuts (refer to page 24)	A4
22.1	Bellows housing	SA 216 WCB
22.2	Mounting bonnet	SA 216 WCB
22.3	Stem- / Bellows unit *	SA 276 Gr.420 / SA 240 Gr.321
22.4	Guide bushing	SA 276 Gr.420 (hardened)
22.5	Guide bushing	SA 276 Gr.420 (hardened)
22.6	Gasket *	Pure graphite (CrNi laminated with graphite)
22.7	Studs	SA 193 B7
22.8	Hexagon nuts	SA 194 2H
22.10	Packing ring *	Pure graphite
22.12	Washer *	SA 240 Gr. 304
22.17	Screw joint *	AISI 303

* Spare parts (Pos. 13-15 will be supplied as unit)

Information / restriction of technical rules need to be observed!

A production allowance acc. to TRB 801 No. 45 exists

The engineer, designing a system or a plant, is responsible for the selection of the correct valve.

max. permissible closing pressures on flow-to-open P2 = 0
 Observe restrictions by Pressure-temperature-ratings, refer to page 23.
 Observe standard values for selection of plugs, refer to page 22.

Nominal diameter		1"						1 1/2"		2"		3"		4"		6"		8"								
Standard Cv-values ³⁾	Seat-Ø (in)						0,98		1,57		1,97		3,15		3,94		5,91		7,87							
	Cv-value						12		29		46		116		185		462		728							
	Travel (in)						0,79		1,18		1,18		1,18		1,18		1,97		2,56							
Reduced Cv-values ³⁾	Seat-Ø (in)	0,12	0,2	0,47	0,71	0,87		0,98	1,26		1,26	1,57		1,97	2,56		2,56	3,15		3,94	4,92		4,92	5,91		
	Cv-value	0,29	0,73	2,9	1,8	4,6	7,3		12	18		18	29		46	73		73	116		185	289		289	462	
	Travel (in)	0,12	0,46	1,2					0,79	0,79		0,79	1,18		1,18	1,18		1,18	1,18		1,18	1,97		1,97	1,97	
Actuator ¹⁾ ARI-PREMIO 495 lbf	Closing pressure (psi)	I.	740	740	740	740	677	521	510	306	191	306	191	117	116	64	39	64	39	22	22					
		II.	740	740	740	740	634	488	466	279	173	279	173	106	103	56	34	56	34	19	19					
	III.	461	457	442	430	421	415	415	262	162	262	162	99	99	54	32	54	32	18	15						
	Operating time ²⁾ (s) (Op. Speed 0,01 in/s)	53						53	79	53	79	79		79		79										
Actuator ¹⁾ ARI-PREMIO 1124 lbf	Closing pressure (psi)	I.					740	740	740	740	502	740	502	318	316	183	118	183	118	73	73	45	29			
		II.					740	740	740	740	484	740	484	306	303	176	113	176	113	70	70	42	28	40	26	
	III.	580	580	580	580	580	580	580	580	473	580	473	299	299	173	111	173	111	69	66	40	26	40	26		
	Operating time ²⁾ (s) (Op. Speed 0,01 in/s)	53						53	79	53	79	79		79		79	132			132						
Actuator ¹⁾ ARI-PREMIO 2698 lbf	Closing pressure (psi)	I.								740		740	740	740	482	316	482	316	200	200	126	86				
		II.								740		740	740	740	474	311	474	311	197	197	124	85	121	83	45	
	III.									580		580	580	580	472	309	472	309	196	193	122	83	122	83	45	
	Operating time ²⁾ (s) (Op. Speed 0,01 in/s)								79		79		79		79		79		79	132			132		171	
Actuator ¹⁾ ARI-PREMIO 3372 lbf	Closing pressure (psi)	I.													610	401	610	401	255	255	161	111				
		II.													602	396	602	396	252	252	159	109	156	107	59	
	III.													580	394	580	394	250	248	157	107	157	107	59		
	Operating time ²⁾ (s) (Op. Speed 0,01 in/s)													79		79		79		79	132			132		171
I. Fig. 470: PTFE-V-ring unit;		II. Fig. 470: PTFE- / Pure graphite-packing;												III. Fig. 471: Bellows seal												

¹⁾ Motor voltage: 230V 50Hz
 Other voltages: 24V 50/60Hz; 115V 50/60Hz; 230V 60Hz
 Technical data for actuator refer to data sheet ARI-PREMIO.

²⁾ Indicated operating times with 50Hz.

³⁾ Not for perforated plug (presentation ref. to page 24). Kvs-values refer to „Selection STEVI“ in the Technical annex.

max. permissible closing pressures on flow-to-open P2 = 0
 Observe restrictions by Pressure-temperature-ratings, refer to page 23.
 Observe standard values for selection of plugs, refer to page 22.

Nominal diameter		DN 25						DN 40		DN 50		DN 80		DN100		DN150		DN200											
Standard Kvs-values ³⁾	Seat-Ø (mm)						25		40		50		80		100		150		200										
	Kvs-value						10		25		40		100		160		400		630										
	Travel (mm)						20		30		30		30		30		50		65										
Reduced Kvs-values ³⁾	Seat-Ø (mm)	3	5	12	18	22		25	32		32	40		50	65		65	80		100	125		125	150					
	Kvs-value	0,25 0,16 0,1	0,63 0,4	2,5 1,6 1	4	6,3		10	16		16	25		40	63		63	100		160	250		250	400					
	Travel (mm)	20	20	20	20	20		20	20		20	30		30	30		30	30		30	50		50	50					
Actuator ¹⁾ ARI-PREMIO 2,2 kN	Closing pressure (bar)	I.	51	51	51	51	46,7	35,9	35,2	21,1	13,2	21,1	13,2	8,1	8	4,4	2,7	4,4	2,7	1,5	1,5								
		II.	51	51	51	51	43,7	33,7	32,1	19,2	11,9	19,2	11,9	7,3	7,1	3,9	2,3	3,9	2,3	1,3	1,3								
		III.	31,8	31,5	30,5	29,6	29,1	28,6	28,6	18	11,2	18	11,2	6,8	6,8	3,7	2,2	3,7	2,2	1,2	1								
Operating time ²⁾ (s) (Op. Speed 0,38 mm/s)		53						53	79	53	79	79		79		79													
Actuator ¹⁾ ARI-PREMIO 5 kN	Closing pressure (bar)	I.					51	51	51	51	34,6	51	34,6	21,9	21,8	12,6	8,2	12,6	8,2	5	5	3,1	2						
		II.					51	51	51	51	33,4	51	33,4	21,1	20,9	12,1	7,8	12,1	7,8	4,8	4,8	2,9	1,9	2,7	1,8				
		III.	40	40	40	40	40	40	40	40	32,6	40	32,6	20,6	20,6	11,9	7,7	11,9	7,7	4,7	4,5	2,8	1,8	2,8	1,8				
Operating time ²⁾ (s) (Op. Speed 0,38 mm/s)		53						53	79	53	79	79		79		79	132	132											
Actuator ¹⁾ ARI-PREMIO 12 kN	Closing pressure (bar)	I.								51		51	51	51	33,2	21,8	33,2	21,8	13,8	13,8	8,7	5,9							
		II.								51		51	51	51	32,7	21,5	32,7	21,5	13,6	13,6	8,6	5,8	8,4	5,7	3,1				
		III.								40		40	40	40	32,5	21,3	32,5	21,3	13,5	13,3	8,4	5,7	8,4	5,7	3,1				
Operating time ²⁾ (s) (Op. Speed 0,38 mm/s)									79		79		79		79		79		79	132	132					171			
Actuator ¹⁾ ARI-PREMIO 15 kN	Closing pressure (bar)	I.													42,1	27,7	42,1	27,7	17,6	17,6	11,1	7,6							
		II.													41,5	27,3	41,5	27,3	17,3	17,3	11	7,5	10,8	7,4	4				
		III.													40	27,2	40	27,2	17,3	17,1	10,8	7,4	10,8	7,4	4,1				
Operating time ²⁾ (s) (Op. Speed 0,38 mm/s)															79		79		79	132	132					171			
I. Fig. 470: PTFE-V-ring unit;		II. Fig. 470: PTFE- / Pure graphite-packing;												III. Fig. 471: Bellows seal															

¹⁾ Motor voltage: 230V 50Hz
 Other voltages: 24V 50/60Hz; 115V 50/60Hz; 230V 60Hz
 Technical data for actuator refer to data sheet ARI-PREMIO.

²⁾ Indicated operating times with 50Hz.

³⁾ Not for perforated plug (presentation ref. to page 24). Kvs-values refer to „Selection STEVI“ in the Technical annex.

Control valve in straightway form with electric actuator AUMA

SAR 07.1/07.5 = 10.4 in 265 mm SAR 07.1/07.5 = 9.8 in 249 mm
 SAR 10.1 = 11.1 in 282 mm SAR 10.1 = 10 in 254 mm

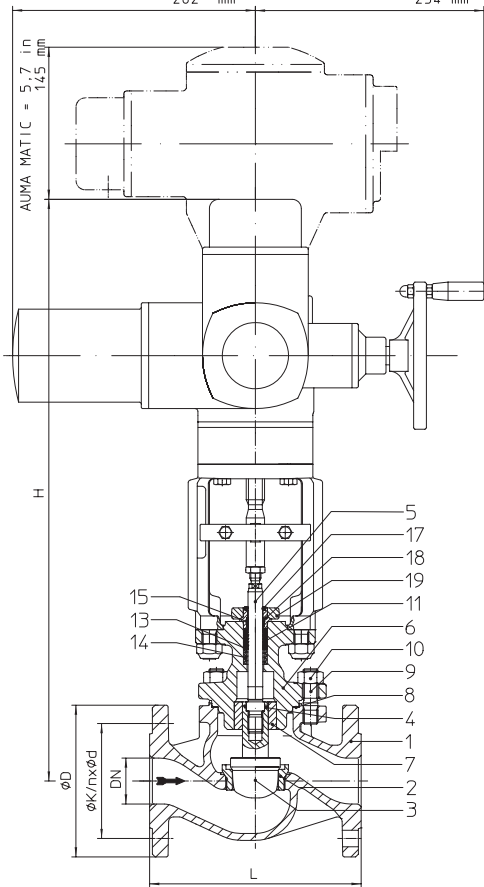

Fig. 470 - ANSI

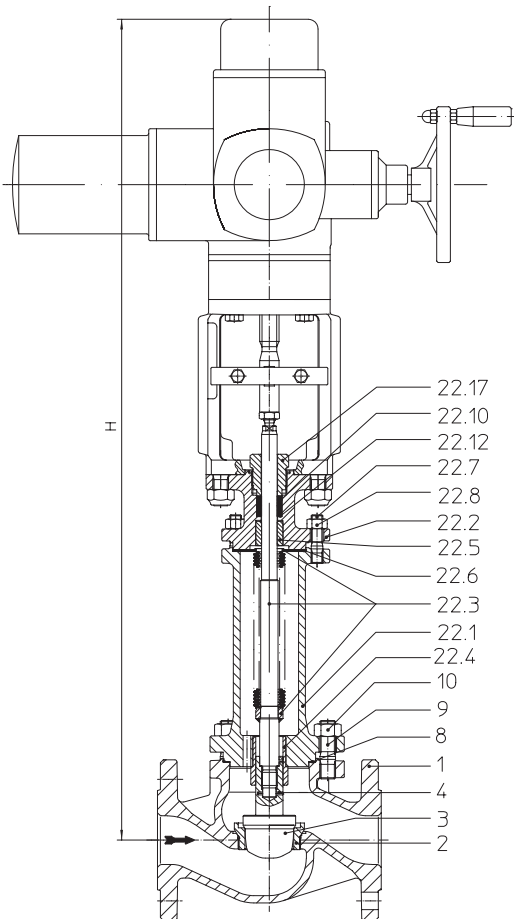

Fig. 471 - ANSI

Figure	Nominal pressure	Material	Nominal diameter
35.470...90 / 35.471...90	ANSI 300	SA 216 WCB	1 1/2" - 8" / DN40-200
Other materials and versions on request.			
Stem sealing			
Fig. 470: <ul style="list-style-type: none"> • PTFE-V-ring unit (to 6" / DN150) +14°F to +428°F / -10°C to +220°C • PTFE-packing +14°F up to +482°F / -10°C up to +250°C • Pure graphite-packing +14°F up to +842°F / -10°C up to +450°C 			
Fig. 471: <ul style="list-style-type: none"> • Stainless steel bellows seal (for restricted pressure range) -76°F up to +842°F / -60°C up to +450°C 			
Plug design standard:			
<ul style="list-style-type: none"> • Parabolic plug, metal seat (1 1/2"-6" / DN40-150) • V-port plug, metal seat (8" / DN200) 			
optional:			
<ul style="list-style-type: none"> • Parabolic plug with PTFE soft seat (max. 392°F / 200°C) (1"-6" / DN25-150) • V-port plug, metal seat (from seat-ø 2,56 in / 65 mm) • Perforated plug, metal seat • Parabolic pressure balanced plug (or perforated plug), metal seat; Material of piston seal: PTFE with stainless steel spring (max. 392°F / 200°C) 			
Guiding			
<ul style="list-style-type: none"> • Parabolic plug: post guiding • Perforated / V-port plug: post and port guiding 			
Flow characteristic			
<ul style="list-style-type: none"> • Equal percentage or linear (from Kvs 100 modified equal percentage, Miniature-Kvs-values ≤ 0,63 only equal percentage) 			
Rangeability			
<ul style="list-style-type: none"> • 50 : 1 on parabolic plug • 30 : 1 on perforated plug / V-port plug 			
Shut off class (seat / plug leakage classes)			
<ul style="list-style-type: none"> • Metal seat - Leakage class IV acc. to ANSI / FCI 70-2 • Soft seat - Leakage class VI acc. to ANSI / FCI 70-2 (from Cv 1,2 / Kvs 1,0) 			
Closing pressures refer to page 8.			
Technical data for actuator refer to data sheet.			

Selection of possible applications

Industrial installations, processing technology, plant manufacturing, etc. (other applications on request)

Selection of possible flow media

Fig. 470-ANSI: Cooling water, cooling brine, warm water, hot water, steam, gas, etc.

Fig. 471-ANSI: Refrigerant, cooling water, warm water, hot water, thermal oil, steam, gas, etc. (other flow media on request)

Dimensions and weights

Nominal diameter			1 1/2"	2"	3"	4"	6"	8"
L		(in)	9,25	10,5	12,5	14,5	18,62	22,38
Fig. 470	H	(in)	25,9	25,9	27	27,1	29,5	33,2
	SAR 07.1	(lb)	98,8	106,5	150,6	207	--	--
	SAR 07.5	(lb)	98,8	106,5	150,6	207	341	544
	H	(in)	--	--	27,5	27,6	30	33,7
	SAR 10.1	(lb)	--	--	160,5	217	351	554
	H	(in)	--	--	--	--	35	36,7
	SAR 14.1	(lb)	--	--	--	--	426	629
Fig. 471	H	(in)	34,2	34,2	34,9	36,1	42,4	50,7
	SAR 07.1	(lb)	108	115,8	163,8	214	359	568
	SAR 07.5	(lb)	108	115,8	163,8	214	359	568
	H	(in)	--	--	35,4	36,6	42,8	51,2
	SAR 10.1	(lb)	--	--	173,8	224	369	578
Nominal diameter			DN 40	DN 50	DN 80	DN100	DN150	DN200
L		(mm)	235	267	318	368	473	568
Fig. 470	H	(mm)	658	658	687	689	749	844
	SAR 07.1	(kg)	44,8	48,3	68,3	94	--	--
	SAR 07.5	(kg)	44,8	48,3	68,3	94	155	247
	H	(mm)	--	--	699	701	761	856
	SAR 10.1	(kg)	--	--	72,8	98	159	251
	H	(mm)	--	--	--	--	888	931
	SAR 14.1	(kg)	--	--	--	--	194	285
Fig. 471	H	(mm)	869	869	887	917	1076	1289
	SAR 07.1	(kg)	49	52,5	74,3	97	163	258
	SAR 07.5	(kg)	49	52,5	74,3	97	163	258
	H	(mm)	--	--	899	929	1088	1301
	SAR 10.1	(kg)	--	--	78,8	102	167	262

Standard-flange dimensions refer to page 23.

(For version with AUMA SAR Ex other heights.)

Face to face dimension Form RF acc. to ANSI / ISA-S75.03 - 1992 (Face to face dimensions for flanges Form RTJ on request.)

Parts

Pos.	Description	Fig. 35.470...90 / Fig. 35.471...90
1	Body	SA 216 WCB
2	Seat ring *	SA 276 Gr.420
3	Plug *	SA 276 Gr.420
4	Straight spin *	A2
5	Stem *	SA 276 Gr.420
6	Mounting bonnet	SA 216 WCB
7	Guide bushing	SA 276 Gr.420 (hardened)
8	Gasket *	Pure graphite (CrNi laminated with graphite)
9	Studs	SA 193 B7
10	Hexagon nuts	SA 194 2H
11	V-ring unit *	PTFE
13	Washer *	SA 240 Gr. 304
14	Spring *	AISI 301 A313 Gr.301
15	Strip *	PTFE25%C
17	Scraper *	PTFE
18	Stem guiding *	AISI 303
19	Packing box flange	SA 105
20	Studs (refer to page 24)	A4-70
21	Hexagon nuts (refer to page 24)	A4
22.1	Bellows housing	SA 216 WCB
22.2	Mounting bonnet	SA 216 WCB
22.3	Stem- / Bellows unit *	SA 276 Gr.420 / SA 240 Gr.321
22.4	Guide bushing	SA 276 Gr.420 (hardened)
22.5	Guide bushing	SA 276 Gr.420 (hardened)
22.6	Gasket *	Pure graphite (CrNi laminated with graphite)
22.7	Studs	SA 193 B7
22.8	Hexagon nuts	SA 194 2H
22.10	Packing ring *	Pure graphite
22.12	Washer *	SA 240 Gr. 304
22.17	Screw joint *	AISI 303

* Spare parts (Pos. 13-15 will be supplied as unit)

Information / restriction of technical rules need to be observed!

A production allowance acc. to TRB 801 No. 45 exists

The engineer, designing a system or a plant, is responsible for the selection of the correct valve.

max. permissible closing pressures on flow-to-open P2 = 0
 Observe restrictions by Pressure-temperature-ratings, refer to page 23.
 Observe standard values for selection of plugs, refer to page 22.

Fig. 470 - ANSI																				
Nominal diameter				1 1/2"		2"		3"		4"		6"		8"						
Standard Cv-values ⁴⁾	Seat-Ø (in)			1,57		1,97		3,15		3,94		5,91		7,87						
	Cv-value			29		46		116		185		462		728						
	Travel (in)			1,18		1,18		1,18		1,18		1,97		2,56						
Reduced Cv-values	Seat-Ø (in)	0,98	1,26		1,26	1,57		1,97	2,56		2,56	3,15		3,94	4,92		4,92	5,91		
	Cv-value	12	18		18	29		46	73		73	116		185	289		289	462		
	Travel (in)	0,79	0,79		0,79	1,18		1,18	1,18		1,18	1,18		1,18	1,97		1,97	1,97		
Actuator ¹⁾ AUMA SAR 07.1 Output drive Form A TR 20 x 4 - LH	Closing pressure (psi)	I./II.	shut off controlling ³⁾	740	740	740	740	740	740	673	443	673	443	282						
				740	740	740	740	740	545	542	318	207	318	207	130					
	Torque (ft lbf)				11		11		15		15		22		22					
	Operating time ²⁾ (s)				54		56		54		56		56		56					
Output drive (rpm)				5,6		8		5,6		8		8		8						
Actuator ¹⁾ AUMA SAR 07.5 Output drive Form A TR 26 x 5 - LH	Closing pressure (psi)	I./II.	shut off controlling ³⁾					740	740	740	624	740	624	398	398	253	175	251	173	96
								740	740	455	298	455	298	189	189	119	81	116	79	43
	Torque (ft lbf)						22		22		37		44		37		44		44	
	Operating time ²⁾ (s)						64		64		64		64		64		55		55	
Output drive (rpm)						5,6		5,6		5,6		5,6		5,6		11		11		
Actuator ¹⁾ AUMA SAR 10.1 Output drive Form A TR 26 x 5 - LH	Closing pressure (psi)	I./II.	shut off controlling ³⁾					740	740	740	740	678	678	433	300	520	360	301		
								740	624	740	624	398	398	253	175	251	173	96		
	Torque (ft lbf)						44		59		44		59		74		74		89	
	Operating time ²⁾ (s)								64		64		64		64		55		55	
Output drive (rpm)								5,6		5,6		5,6		5,6		11		11		
Actuator ¹⁾ AUMA SAR 14.1 Output drive Form A TR 30 x 6 - LH	Closing pressure (psi)	I./II.	shut off controlling ³⁾											740	740	620	740	620	348	
																656	419	290	419	290
	Torque (ft lbf)														111		166		184	
	Operating time ²⁾ (s)														38		63		63	
Output drive (rpm)														8		8		11		

I. Fig. 470: PTFE-V-ring unit; II. Fig. 470: PTFE- / Pure graphite-packing

Fig. 471 - ANSI																				
Nominal diameter				1 1/2"		2"		3"		4"		6"		8"						
Standard Cv-values ⁴⁾	Seat-Ø (in)			1,57		1,97		3,15		3,94		5,91		7,87						
	Cv-value			29		46		116		185		462		728						
	Travel (in)			1,18		1,18		1,18		1,18		1,97		2,56						
Reduced Cv-values	Seat-Ø (in)	0,98	1,26		1,26	1,57		1,97	2,56		2,56	3,15		3,94	4,92		4,92	5,91		
	Cv-value	12	18		18	29		46	73		73	116		185	289		289	462		
	Travel (in)	0,79	0,79		0,79	1,18		1,18	1,18		1,18	1,18		1,18	1,97		1,97	1,97		
Actuator ¹⁾ AUMA SAR 07.1 Output drive Form A TR 20 x 4 - LH	Closing pressure (psi)	III.	shut off controlling ³⁾	580	580	580	580	580	580	580	441	580	441	281						
				580	580	580	580	580	538	538	315	206	315	206	129					
	Torque (ft lbf)				11		11		15		15		22		22					
	Operating time ²⁾ (s)				54		56		54		56		56		56					
Output drive (rpm)				5,6		8		5,6		8		8		8						
Actuator ¹⁾ AUMA SAR 07.5 Output drive Form A TR 26 x 5 - LH	Closing pressure (psi)	III.	shut off controlling ³⁾					580	580	580	580	580	397	395	251	173	251	173	96	
								580	580	452	296	452	296	188	185	116	79	116	79	43
	Torque (ft lbf)						22		22		30		44		30		44		44	
	Operating time ²⁾ (s)						64		64		64		64		64		55		55	
Output drive (rpm)						5,6		5,6		5,6		5,6		5,6		11		11		
Actuator ¹⁾ AUMA SAR 10.1 Output drive Form A TR 26 x 5 - LH	Closing pressure (psi)	III.	shut off controlling ³⁾					580	580	580	580	467	580	430	298	386	267	149		
								580	580	580	580	397	395	251	173	251	173	96		
	Torque (ft lbf)								44		44		52		66		74		66	
	Operating time ²⁾ (s)								64		64		64		64		55		55	
Output drive (rpm)								5,6		5,6		5,6		5,6		11		11		

III. Fig. 471: Bellows seal

(Higher closing pressures for 6" in connection with AUMA SAR 14.1 on request)

¹⁾ Motor voltage: 400V 50Hz 3-
 (Other voltages on request)
 Technical data for actuator refer to price list.

²⁾ Indicated operating times with 50Hz.

³⁾ Restrictions through max. permissible torque of the actuator at controlling operation.

⁴⁾ Not for perforated plug (presentation ref. to page 24). Kvs-values refer to „Selection STEVI“ in the Technical annex.

max. permissible closing pressures on flow-to-open P2 = 0
Observe restrictions by Pressure-temperature-ratings, refer to page 23.
Observe standard values for selection of plugs, refer to page 22.

Fig. 470 - ANSI																								
Nominal diameter			DN 40			DN 50			DN 80			DN100			DN150			DN200						
Standard Kvs-values ⁴⁾	Seat-Ø (mm)		40			50			80			100			150			200						
	Kvs-value		25			40			100			160			400			630						
	Travel (mm)		30			30			30			30			50			65						
Reduced Kvs-values	Seat-Ø (mm)		25	32	32	40	50	65	65	80	100	125	125	150	125	150								
	Kvs-value		10	16	16	25	40	63	63	100	160	250	250	400	250	400								
	Travel (mm)		20	20	20	30	30	30	30	30	30	50	50	50	50	50								
Actuator ¹⁾ AUMA SAR 07.1 Output drive Form A TR 20 x 4 - LH	Closing pressure (bar)	I./II.	shut off		51	51	51	51	51	51	46,4	30,6	46,4	30,6	19,4									
			controlling ³⁾		51	51	51	51	51	37,6	37,4	21,9	14,3	21,9	14,3	9								
	Torque (Nm)		15			15			20			20			30			30						
	Operating time ²⁾ (s)		54		56		54		56		56			56										
Output drive (rpm)		5,6		8		5,6		8		8			8											
Actuator ¹⁾ AUMA SAR 07.5 Output drive Form A TR 26 x 5 - LH	Closing pressure (bar)	I./II.	shut off						51	51	51	43,1	51	43,1	27,5	27,5	17,5	12	17,3	11,9	6,6			
			controlling ³⁾						51	51	31,3	20,6	31,3	20,6	13	13	8,2	5,6	8	5,5	2,9			
	Torque (Nm)								30			30			50			60			60			
	Operating time ²⁾ (s)								64		64			64			64			55		55		71
Output drive (rpm)								5,6		5,6			5,6			5,6		11		11				
Actuator ¹⁾ AUMA SAR 10.1 Output drive Form A TR 26 x 5 - LH	Closing pressure (bar)	I./II.	shut off						51	51	51	51	46,7	46,7	29,8	20,7	35,8	24,8	13,9					
			controlling ³⁾						51	43,1	51	43,1	27,5	27,5	17,5	12	17,3	11,9	6,6					
	Torque (Nm)								60			80			100			100			120			
	Operating time ²⁾ (s)								64		64			64			55		55		71			
Output drive (rpm)								5,6		5,6			5,6			11		11						
Actuator ¹⁾ AUMA SAR 14.1 Output drive Form A TR 30 x 6 - LH	Closing pressure (bar)	I./II.	shut off												51	51	42,7	51	42,7	24				
			controlling ³⁾													45,2	28,9	20	28,9	20	11,1			
	Torque (Nm)														150			225		250		225		250
	Operating time ²⁾ (s)														38		63		63		59			
Output drive (rpm)														8		8		11		11				

I. Fig. 470: PTFE-V-ring unit;

II. Fig. 470: PTFE- / Pure graphite-packing

Fig. 471 - ANSI																							
Nominal diameter			DN 40			DN 50			DN 80			DN100			DN150			DN200					
Standard Kvs-values ⁴⁾	Seat-Ø (mm)		40			50			80			100			150			200					
	Kvs-value		25			40			100			160			400			630					
	Travel (mm)		30			30			30			30			50			65					
Reduced Kv ⁶⁾ -values	Seat-Ø (mm)		25	32	32	40	50	65	65	80	100	125	125	150	125	150							
	Kvs-value		10	16	16	25	40	63	63	100	160	250	250	400	250	400							
	Travel (mm)		20	20	20	30	30	30	30	30	30	50	50	50	50	50							
Actuator ¹⁾ AUMA SAR 07.1 Output drive Form A TR 20 x 4 - LH	Closing pressure (bar)	III.	shut off		40	40	40	40	40	40	30,4	40	30,4	19,4									
			controlling ³⁾		40	40	40	40	40	37,1	37,1	21,7	14,2	21,7	14,2	8,9							
	Torque (Nm)		15			15			20			20			30			30					
	Operating time ²⁾ (s)		54		56		54		56		56			56									
Output drive (rpm)		5,6		8		5,6		8		8			8										
Actuator ¹⁾ AUMA SAR 07.5 Output drive Form A TR 26 x 5 - LH	Closing pressure (bar)	III.	shut off						40	40	40	40	40	27,4	27,2	17,3	11,9	17,3	11,9	6,6			
			controlling ³⁾						40	40	31,2	20,4	31,2	20,4	12,9	12,7	8	5,5	8	5,5	3		
	Torque (Nm)								30			30			40			60			60		
	Operating time ²⁾ (s)								64		64			64			55		55		71		
Output drive (rpm)								5,6		5,6			5,6			11		11					
Actuator ¹⁾ AUMA SAR 10.1 Output drive Form A TR 26 x 5 - LH	Closing pressure (bar)	III.	shut off						40	40	40	40	32,2	40	29,7	20,5	26,6	18,4	10,2				
			controlling ³⁾						40	40	40	40	27,4	27,2	17,3	11,9	17,3	11,9	6,6				
	Torque (Nm)								60			60			70			90			90		
	Operating time ²⁾ (s)								64		64			64			55		55		71		
Output drive (rpm)								5,6		5,6			5,6			11		11					

III. Fig. 471: Bellows seal

(Higher closing pressures for DN150 in connection with AUMA SAR 14.1 on request)

¹⁾ Motor voltage: 400V 50Hz 3~
(Other voltages on request)
Technical data for actuator refer to price list.

²⁾ Indicated operating times with 50Hz.

³⁾ Restrictions through max. permissible torque of the actuator at controlling operation.

⁴⁾ Not for perforated plug (presentation ref. to page 24). Kvs-values refer to „Selection STEVI“ in the Technical annex.

Control valve in straightway form with pneumatic actuator DP

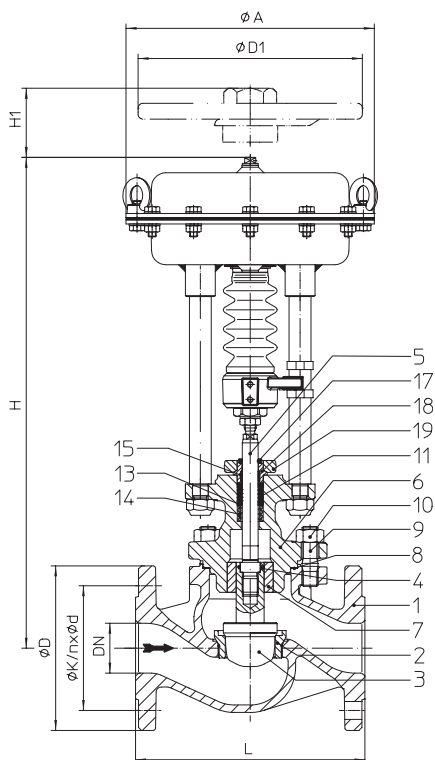

Fig. 470 - ANSI

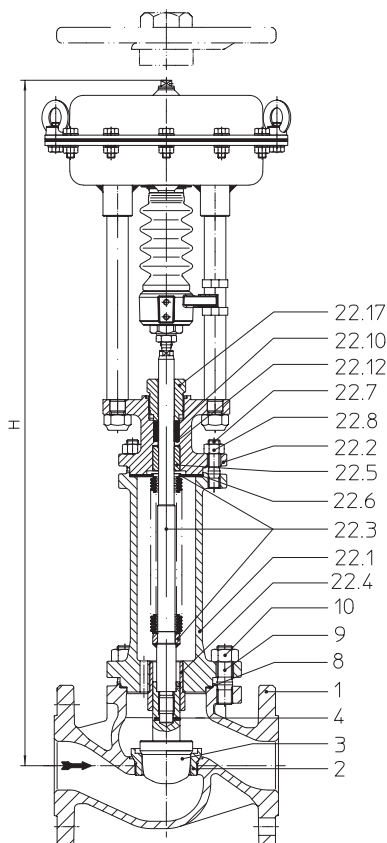

Fig. 471 - ANSI

Figure	Nominal pressure	Material	Nominal diameter
35.470...90 / 35.471...90	ANSI 300	SA 216 WCB	1" - 6" / DN25-150
Other materials and versions on request.			
Stem sealing			
Fig. 470: <ul style="list-style-type: none"> • PTFE-V-ring unit (to 6" / DN150) +14°F to +428°F / -10°C to +220°C • PTFE-packing +14°F up to +482°F / -10°C up to +250°C • Pure graphite-packing +14°F up to +842°F / -10°C up to +450°C 			
Fig. 471: <ul style="list-style-type: none"> • Stainless steel bellows seal (for restricted pressure range) -76°F up to +842°F / -60°C up to +450°C 			
Plug design standard: <ul style="list-style-type: none"> • Parabolic plug, metal seat optional: <ul style="list-style-type: none"> • Parabolic plug with PTFE soft seat (max. 392°F / 200°C) • V-port plug, metal seat (from seat-ø 2,56 in / 65 mm) • Perforated plug, metal seat • Parabolic pressure balanced plug (or perforated plug), metal seat; Material of piston seal: PTFE with stainless steel spring (max. 392°F / 200°C) 			
Guiding <ul style="list-style-type: none"> • Parabolic plug: post guiding • Perforated / V-port plug: post and port guiding 			
Flow characteristic <ul style="list-style-type: none"> • Equal percentage or linear (from Kvs 100 modified equal percentage, Miniature-Kvs-values ≤ 0,63 only equal percentage) 			
Rangeability <ul style="list-style-type: none"> • 50 : 1 on parabolic plug • 30 : 1 on perforated plug / V-port plug 			
Shut off class (seat / plug leakage classes) <ul style="list-style-type: none"> • Metal seat - Leakage class IV acc. to ANSI / FCI 70-2 • Soft seat - Leakage class VI acc. to ANSI / FCI 70-2 (from Cv 1,2 / Kvs 1,0) 			
Closing pressures refer to page 12-15.			
Technical data for actuator refer to data sheet.			

Selection of possible applications

Industrial installations, processing technology, plant manufacturing, etc. (other applications on request)

Selection of possible flow media

Fig. 470-ANSI: Cooling water, cooling brine, warm water, hot water, steam, gas, etc.

Fig. 471-ANSI: Refrigerant, cooling water, warm water, hot water, thermal oil, steam, gas, etc.

(other flow media on request)

Top mounted handwheel

Actuator		DP32	DP33	DP34
Ø D1	(in)	8,9	11,8	15,7
H1	(in)	10,6	11,2	17,4
Weight	(lb)	11,3	17,6	37,5
Actuator		DP32	DP33	DP34
Ø D1	(mm)	225	300	400
H1	(mm)	270	284	442
Weight	(kg)	5	8	17
Technical data for actuator refer to data sheet DP32-34Tri.				

Dimensions and weights

Nominal diameter			1"	1 1/2"	2"	3"	4"	6"	
L			(in)	7,75	9,25	10,5	12,5	14,5	18,62
DP32	Ø A		(in)	9,8					
	Fig. 470	H	(in)	18,6	19,8	19,8	20,5	21,1	23
		Weight	(lb)	43	60,6	65	109,1	165	300
	Fig. 471	H	(in)	24,8	28,1	28,1	28,4	29,6	35,9
Weight		(lb)	49,2	69,9	74,3	122,4	173	318	
DP33	Ø A		(in)	11,8					
	Fig. 470	H	(in)	20,8	22	22	23,1	23,2	25,6
		Weight	(lb)	56,2	73,9	78,3	122,4	179	313
	Fig. 471	H	(in)	27	30,3	30,3	31	32,2	38,5
Weight		(lb)	62,4	83,1	87,5	135,6	186	331	
DP34	Ø A		(in)	15,9					
	Fig. 470	H	(in)	--	27,3	27,3	28,5	28,5	30,9
		Weight	(lb)	--	140	144,4	188,5	245	379
	Fig. 471	H	(in)	--	35,6	35,6	36,3	37,5	43,8
Weight		(lb)	--	149,3	153,7	201,8	252	397	
Nominal diameter			DN 25	DN 40	DN 50	DN 80	DN100	DN150	
L			(mm)	197	235	267	318	368	473
DP32	Ø A		(mm)	250					
	Fig. 470	H	(mm)	473	504	504	522	524	584
		Weight	(kg)	19,5	27,5	29,5	49,5	75	136
	Fig. 471	H	(mm)	630	715	715	722	752	911
Weight		(kg)	22,3	31,7	33,7	55,5	78	144	
DP33	Ø A		(mm)	300					
	Fig. 470	H	(mm)	528	559	559	588	590	650
		Weight	(kg)	25,5	33,5	35,5	55,5	81	142
	Fig. 471	H	(mm)	685	770	770	788	818	977
Weight		(kg)	28,3	37,7	39,7	61,5	84	150	
DP34	Ø A		(mm)	405					
	Fig. 470	H	(mm)	--	694	694	723	725	785
		Weight	(kg)	--	63,5	65,5	85,5	111	172
	Fig. 471	H	(mm)	--	905	905	923	953	1112
Weight		(kg)	--	67,7	69,7	91,5	114	180	

Standard-flange dimensions refer to page 23.

Face to face dimension Form RF acc. to ANSI / ISA-S75.03 - 1992 (Face to face dimensions for flanges Form RTJ on request.)

Parts

Pos.	Description	Fig. 35.470...90 / Fig. 35.471...90
1	Body	SA 216 WCB
2	Seat ring *	SA 276 Gr.420
3	Plug *	SA 276 Gr.420
4	Straight spin *	A2
5	Stem *	SA 276 Gr.420
6	Mounting bonnet	SA 216 WCB
7	Guide bushing	SA 276 Gr.420 (hardened)
8	Gasket *	Pure graphite (CrNi laminated with graphite)
9	Studs	SA 193 B7
10	Hexagon nuts	SA 194 2H
11	V-ring unit *	PTFE
13	Washer *	SA 240 Gr. 304
14	Spring *	AISI 301 A313 Gr.301
15	Strip *	PTFE25%C
17	Scraper *	PTFE
18	Stem guiding *	AISI 303
19	Packing box flange	SA 105
20	Studs (refer to page 24)	A4-70
21	Hexagon nuts (refer to page 24)	A4
22.1	Bellows housing	SA 216 WCB
22.2	Mounting bonnet	SA 216 WCB
22.3	Stem- / Bellows unit *	SA 276 Gr.420 / SA 240 Gr.321
22.4	Guide bushing	SA 276 Gr.420 (hardened)
22.5	Guide bushing	SA 276 Gr.420 (hardened)
22.6	Gasket *	Pure graphite (CrNi laminated with graphite)
22.7	Studs	SA 193 B7
22.8	Hexagon nuts	SA 194 2H
22.10	Packing ring *	Pure graphite
22.12	Washer *	SA 240 Gr. 304
22.17	Screw joint *	AISI 303

Information / restriction of technical rules need to be observed!

A production allowance acc. to TRB 801 No. 45 exists

The engineer, designing a system or a plant, is responsible for the selection of the correct valve.

* Spare parts (Pos. 13-15 will be supplied as unit)

Control valve in straightway form with pneumatic actuator DP

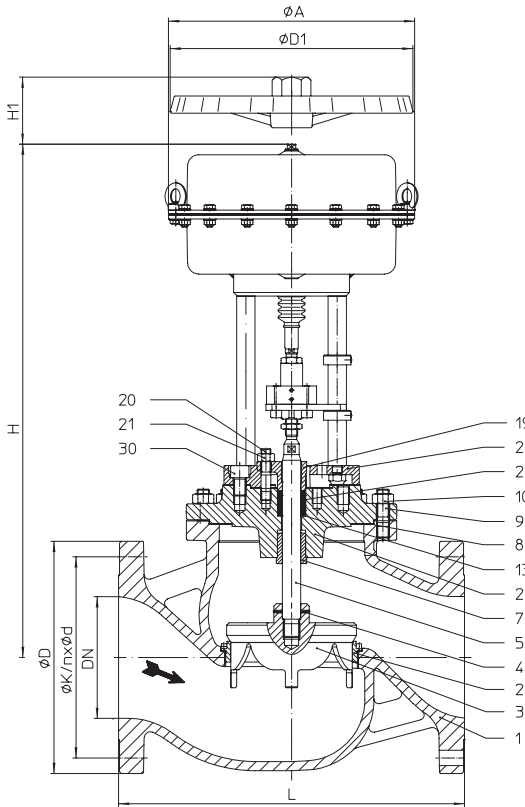

Fig. 470 - ANSI

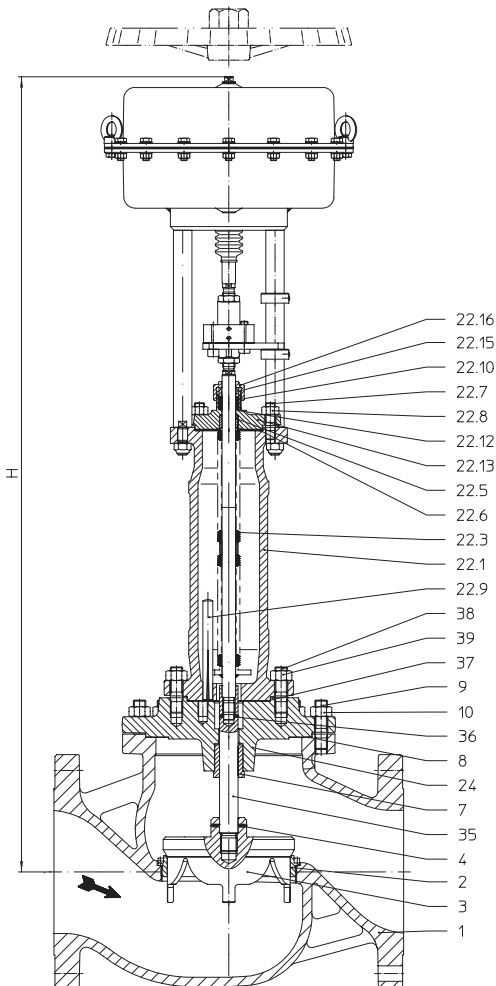

Fig. 471 - ANSI

Figure	Nominal pressure	Material	Nominal diameter
35.470...90 / 35.471...90	ANSI 300	SA 216 WCB	6"v - 8" / DN150v-200
Other materials and versions on request.			
Stem sealing			
Fig. 470: • PTFE-packing +14°F up to +482°F / -10°C up to +250°C • Pure graphite-packing +14°F up to +842°F / -10°C up to +450°C			
Fig. 471: • Stainless steel-bellow (for restricted pressure range) -76°F to +842°F / -60°C to +450°C			
Plug design standard:			
• Parabolic plug, metal seat (6"v / DN150v) • V-port plug, metal seat (8" / DN200)			
optional:			
• Parabolic plug with PTFE soft seat (max. 392°F / 200°C) (6"v / DN150v) • V-port plug, metal seat (6"v / DN150v) • Perforated plug, metal seat • Parabolic pressure balanced plug (or perforated plug), metal seat; Material of piston seal: PTFE with stainless steel spring (max. 392°F / 200°C)			
Guiding			
• Parabolic plug: post guiding • Perforated / V-port plug: post and port guiding			
Flow characteristic			
• Equal percentage or linear (from Kvs 100 modified equal percentage, Miniature-Kvs-values ≤ 0,63 only equal percentage)			
Rangeability			
• 50 : 1 on parabolic plug • 30 : 1 on perforated plug / V-port plug			
Shut off class (seat / plug leakage classes)			
• Metal seat - Leakage class IV acc. to ANSI / FCI 70-2 • Soft seat - Leakage class VI acc. to ANSI / FCI 70-2 (from Cv 1,2 / Kvs 1,0)			
Closing pressures refer to page 18-21.			
Technical data for actuator refer to data sheet.			

Selection of possible applications

Industrial installations, processing technology, plant manufacturing, etc.
(other applications on request)

Selection of possible flow media

Fig. 470-ANSI: Cooling water, cooling brine, warm water, hot water, steam, gas, etc.

Fig. 471-ANSI: Refrigerant, cooling water, warm water, hot water, thermal oil, steam, gas, etc.

(other flow media on request)

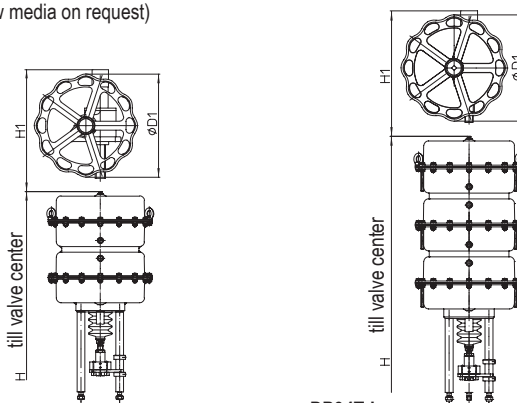

DP34T

DP34Tri

Top mounted handwheel

Actuator		DP34	DP34T	DP34Tri
Ø D1	(in)	15,7	15,7	15,7
H1	(in)	17,4	24,2	24,2
Weight	(lb)	37,5	90,4	90,4
Actuator		DP34	DP34T	DP34Tri
Ø D1	(mm)	400	400	400
H1	(mm)	460	615	615
Weight	(kg)	17	41	41
Technical data for actuator refer to data sheet DP32-34Tri.				

Dimensions and weights

Nominal diameter			6"v	8"	Nominal diameter			DN150v	DN200		
L			(in)	18,62	22,38	L			(mm)	473	568
DP34	Ø A		(in)	--	15,9	DP34	Ø A		(mm)	--	405
		Fig. 470	H	(in)	--			33,2	Fig. 470	H	(mm)
	Weight		(lb)	--	582		Fig. 471	H		(mm)	--
	Fig. 471	H	(in)	--	49,3			Fig. 471	Weight	(kg)	--
Weight		(lb)	--	606							
DP34T	Ø A		(in)	15,9		DP34T	Ø A		(mm)	405	
		Fig. 470	H	(in)	41,4			43,1	Fig. 470	H	(mm)
	Weight		(lb)	536	739		Fig. 471	H		(mm)	1498
	Fig. 471	H	(in)	59	60,7			Fig. 471	Weight	(kg)	251
Weight		(lb)	554	763							
DP34Tri	Ø A		(in)	15,9		DP34Tri	Ø A		(mm)	405	
		Fig. 470	H	(in)	50,1			51,8	Fig. 470	H	(mm)
	Weight		(lb)	611	814		Fig. 471	H		(mm)	1720
	Fig. 471	H	(in)	67,7	69,4			Fig. 471	Weight	(kg)	285
Weight		(lb)	628	838							

Standard-flange dimensions refer to page 23.

Face to face dimension Form RF acc. to ANSI / ISA-S75.03 - 1992 (Face to face dimensions for flanges Form RTJ on request.)

Parts

Pos.	Description	Fig. 35.470...90 / Fig. 35.471...90
1	Body	SA 216 WCB
2	Seat ring *	SA 276 Gr.420
3	Plug *	SA 276 Gr.420
4	Straight spin *	AISI 301 A313 Gr.301
5	Stem *	SA 276 Gr.420
7	Guide bushing	SA 276 Gr.420 (hardened)
8	Gasket *	Pure graphite (CrNi laminated with graphite)
9	Studs	SA 193 B7
10	Hexagon nuts	SA 194 2H
13	Washer *	SA 240 Gr. 304
19	Packing box flange	SA 105
20	Studs	A4-70
21	Hexagon nuts	A4
22.1	Bellows housing	SA 216 WCB
22.3	Stem- / Bellows unit *	SA 276 Gr.420 / SA 240 Gr.321
22.5	Guide bushing	SA 276 Gr.420 (hardened)
22.6	Gasket *	Pure graphite (CrNi laminated with graphite)
22.7	Studs	SA 193 B7
22.8	Hexagon nuts	SA 194 2H
22.9	Straight pin	St
22.10	Packing ring *	Pure graphite
22.12	Washer *	SA 240 Gr. 304
22.13	Stuffing box housing	SA 216 WCB
22.15	Packing follower	SA 276 Gr.420
22.16	Sleeve nut	AISI 1213
24	Stuffing box housing	SA 216 WCB
26	Packing ring *	PTFE
29	Adapter flange	SA 395
30	Hexagon socket head screw	8.8
35	Stem adapter *	SA 276 Gr.420
36	Straight spin *	AISI 301 A313 Gr.301
37	Gasket *	Pure graphite (CrNi laminated with graphite)
38	Studs	SA 193 B7
39	Hexagon nuts	SA 194 2H

* Spare parts

Information / restriction of technical rules need to be observed!

A production allowance acc. to TRB 801 No. 45 exists

The engineer, designing a system or a plant, is responsible for the selection of the correct valve.

max. permissible closing pressures on flow-to-open P2 = 0
 Observe restrictions by Pressure-temperature-ratings, refer to page 23.
 Observe standard values for selection of plugs, refer to page 22.

Spring closes on air failure

Nominal diameter		6"v			8"						
Standard Cv-values ³⁾	Seat-Ø (in)			5,91			7,87				
	Cv-value			462			728				
	Travel (in)			1,97			2,56				
Reduced Cv-values ³⁾	Seat-Ø (in)	3,94	4,92		4,92	5,91					
	Cv-value	185	289		289	462					
	Travel (in)	1,18	1,97		1,97	1,97					
Actuator DP34	Spring range (psi)	Air supply pressure min. (psi)	6 - 17	20	II.		18				
					III.		18 a)				
			12 - 35	39	II.		55	36			
					III.		55	37			
			15 - 29	35	II.				26		
					III.				26		
			22 - 44	48	II.		119	81			
					III.		119	81			
			29 - 58	65	II.		165	113	62		
					III.		165	113	62		
Actuator DP34T	Spring range (psi)	Air supply pressure min. (psi)	3 - 15	22	II.	32 b)	18 b)		18 b)		
					III.	32 e)	18 e)		18 e)		
			6 - 17	25	II.	89 b)	55 b)	36 b)	55 b)	36 b)	19 b)
					III.	89 d)	55 d)	37 d)	55 d)	37 d)	19 d)
			12 - 35	42	II.	203	128	87	128	87	
					III.	203 b)	128 b)	88 b)	128 b)	88 b)	
			15 - 29	36	II.						62 a)
					III.						62 c)
			22 - 44	51	II.		256	177	256	177	
					III.		256 a)	177 a)	256 a)	177 a)	
			30 - 44	51	II.	574					
					III.	574 a)					
29 - 58	65	II.		348	240	348	240	134			
		III.		348	241	348	241	134			
35 - 52	59	II.	659								
		III.									
Actuator DP34Tri	Spring range (psi)	Air supply pressure min. (psi)	3 - 15	22	II.	60 d)	36 d)	24 d)	36 d)	24 d)	
					III.	61 f)	37 f)	24 f)	37 f)	24 f)	
			6 - 17	25	II.	146 d)	91 d)	62 d)	91 d)	62 d)	33 d)
					III.	146 f)	92 f)	62 f)	92 f)	62 f)	33 f)
			12 - 35	42	II.	317 b)	201 b)	138 b)	201 b)	138 b)	76 b)
					III.	318 d)	202 d)	139 d)	202 d)	139 d)	76 d)
			15 - 29	36	II.						98 b)
					III.						98 d)
			22 - 44	51	II.		394 a)	272 a)	394 a)	272 a)	
					III.		394 b)	272 b)	394 b)	272 b)	
			30 - 44	51	II.	740 a)					
					III.						
29 - 58	65	II.		531 a)	368 a)	531 a)	268 a)				
		III.									

II. Fig. 470: PTFE- / Pure graphite-packing;
III. Fig. 471: Bellows seal

Air supply pressure max. of pneumatic actuators DP:

max. permissible 87psi (DP34Tri: max. permissible 73 psi)

Air supply pressure max. limit of control valve:

max. permissible a) 73 psi b) 65 psi c) 58 psi d) 51 psi e) 44 psi f) 36 psi

³⁾ Not for perforated plug (presentation ref. to page 24). Kvs-values refer to „Selection STEVI“ in the Technical annex.

max. permissible closing pressures on flow-to-open P2 = 0
 Observe restrictions by Pressure-temperature-ratings, refer to page 23.
 Observe standard values for selection of plugs, refer to page 22.

Spring opens on air failure

Nominal diameter		6"v			8"				
Standard Cv-values ³⁾	Seat-Ø (in)			5,91			7,87		
	Cv-value			462			728		
	Travel (in)			1,97			2,56		
Reduced Cv-values ³⁾	Seat-Ø (in)	3,94	4,92		4,92	5,91			
	Cv-value	185	289		289	462			
	Travel (in)	1,18	1,97		1,97	1,97			
Actuator DP34	Air supply pressure min. (psi)	20	II.			18			
			III.			18 a)			
		29	II.			73	49	26	
			III.			73 a)	49 a)	26 a)	
		44	II.			165	113	62	
			III.			165 a)	113 a)	62 a)	
		58	II.			256	177	98	
III.				256 a)	177 a)	98 a)			
73	II.			348	240	134			
	III.			348 a)	241 a)	134 a)			
87	II.			439	304	170			
Actuator DP34T	Air supply pressure min. (psi)	22	II.	117 b)	73 b)	49 b)	73 b)	49 b)	26 b)
			III.	118 e)	73 e)	49 e)	73 e)	49 e)	26 e)
		29	II.	260 b)	165 b)	113 b)	165 b)	113 b)	62 b)
			III.	260 e)	165 e)	113 e)	165 e)	113 e)	62 e)
		44	II.	545 b)	348 b)	240 b)	348 b)	240 b)	134 b)
			III.	546 e)	348 e)	241 e)	348 e)	241 e)	134 e)
58	II.	740 b)	531 b)	368 b)	531 b)	368 b)	206 b)		

II. Fig. 470: PTFE- / Pure graphite-packing;
III. Fig. 471: Bellows seal

Air supply pressure max. of pneumatic actuators DP:

max. permissible 87psi

Air supply pressure max. limit of control valve:

max. permissible a) 73 psi b) 65 psi c) 58 psi d) 51 psi e) 44 psi

³⁾ Not for perforated plug (presentation ref. to page 24). Kvs-values refer to „Selection STEVI“ in the Technical annex.

max. permissible closing pressures on flow-to-open P2 = 0
 Observe restrictions by Pressure-temperature-ratings, refer to page 23.
 Observe standard values for selection of plugs, refer to page 22.

Spring closes on air failure

Nominal diameter		DN150v				DN200					
Standard Kvs-values ³⁾	Seat-Ø (mm)			150			200				
	Kvs-value			400			630				
	Travel (mm)			50			65				
Reduced Kvs-values ³⁾	Seat-Ø (mm)	100	125		125	150					
	Kvs-value	160	250		250	400					
	Travel (mm)	30	50		50	50					
Actuator DP34	Spring range (bar)	Air supply pressure min. (bar)	0,4-1,2	1,4	II.			1,2			
					III.			1,3 a)			
			0,8-2,4	2,7	II.			3,8	2,5		
					III.			3,8	2,5		
			1,0-2,0	2,4	II.					1,8	
					III.					1,8	
			1,5-3,0	3,3	II.		8,2	5,6			
					III.		8,2	5,6			
			2,0-4,0	4,5	II.		11,3	7,8	4,3		
					III.		11,4	7,8	4,3		
Actuator DP34T	Spring range (bar)	Air supply pressure min. (bar)	0,2-1,0	1,5	II.	2,2 b)	1,2 b)		1,2 b)		
					III.	2,2 e)	1,3 e)		1,3 e)		
			0,4-1,2	1,7	II.	6,1 b)	3,8 b)	2,5 b)	3,8 b)	2,5 b)	1,3 b)
					III.	6,2 d)	3,8 d)	2,5 d)	3,8 d)	2,5 d)	1,3 d)
			0,8-2,4	2,9	II.	14	8,8	6	8,8	6	
					III.	14 b)	8,8 b)	6 b)	8,8 b)	6 b)	
			1,0-2,0	2,5	II.						4,3a)
					III.						4,3c)
			1,5-3,0	3,5	II.		17,7	12,2	17,7	12,2	
					III.		17,7 a)	12,2 a)	17,7 a)	12,2 a)	
2,1-3,0	3,5	II.	39,6								
		III.	39,6 a)								
2,0-4,0	4,5	II.		24	16,6	24	16,6	9,2			
		III.		24	16,6	24	16,6	9,2			
2,4-3,6	4,1	II.	45,5								
		III.									
Actuator DP34Tri	Spring range (bar)	Air supply pressure min. (bar)	0,2-1,0	1,5	II.	4,1 d)	2,5 d)	1,6 d)	2,5 d)	1,6 d)	
					III.	4,2 f)	2,5 f)	1,6 f)	2,5 f)	1,6 f)	
			0,4-1,2	1,7	II.	10,1 d)	6,3 d)	4,3 d)	6,3 d)	4,3 d)	2,3 d)
					III.	10,1 f)	6,3 f)	4,3 f)	6,3 f)	4,3 f)	2,3 f)
			0,8-2,4	2,9	II.	21,9 b)	13,9 b)	9,5 b)	13,9 b)	9,5 b)	5,3 b)
					III.	21,9 d)	13,9 d)	9,6 d)	13,9 d)	9,6 d)	5,3 d)
			1,0-2,0	2,5	II.						6,7 b)
					III.						6,8 d)
1,5-3,0	3,5	II.		27,1 a)	18,8 a)	27,1 a)	18,8 a)				
		III.		27,2 b)	18,8 b)	27,2 b)	18,8 b)				
2,1-3,0	3,5	II.	51 a)								
2,0-4,0	4,5	II.		36,6 a)	25,4 a)	36,6 a)	25,4 a)	14,2 a)			

II. Fig. 470: PTFE- / Pure graphite-packing;
III. Fig. 471: Bellows seal

Air supply pressure max. of pneumatic actuators DP:

max. permissible 6 bar (DP34Tri: max. permissible 5 bar)

Air supply pressure max. limit of control valve:

max. permissible a) 5 bar b) 4,5 bar c) 4 bar d) 3,5 bar e) 3 bar f) 2,5 bar

³⁾ Not for perforated plug (presentation ref. to page 24). Kvs-values refer to „Selection STEVI“ in the Technical annex.

max. permissible closing pressures on flow-to-open P2 = 0
Observe restrictions by Pressure-temperature-ratings, refer to page 23.
Observe standard values for selection of plugs, refer to page 22.

Spring opens on air failure										
Nominal diameter			DN150v				DN200			
Standard Kvs-values ³⁾	Seat-Ø (mm)				150				200	
	Kvs-value				400				630	
	Travel (mm)				50				65	
Reduced Kvs-values ³⁾	Seat-Ø (mm)		100	125		125	150			
	Kvs-value		160	250		250	400			
	Travel (mm)		30	50		50	50			
Actuator DP34	Air supply pressure min. (bar)	1,4	II.				1,2			
			III.				1,3 a)			
		2	II.				5	3,4	1,8	
			III.				5,1 a)	3,4 a)	1,8 a)	
		3	II.				11,3	7,8	4,3	
			III.				11,4 a)	7,8 a)	4,3 a)	
		4	II.				17,7	12,2	6,7	
			III.				17,7 a)	12,2 a)	6,8 a)	
		5	II.				24	16,6	9,2	
			III.				24 a)	16,6 a)	9,2 a)	
		6	II.				30,3	21	11,7	
			III.							
Actuator DP34T	Air supply pressure min. (bar)	1,5	II.	8,1 b)	5 b)	3,4 b)	5 b)	3,4 b)	1,8 b)	
			III.	8,1 e)	5,1 e)	3,4 e)	5,1 e)	3,4 e)	1,8 e)	
		2	II.	17,9 b)	11,3 b)	7,8 b)	11,3 b)	7,8 b)	4,3 b)	
			III.	18 e)	11,4 e)	7,8 e)	11,4 e)	7,8 e)	4,3 e)	
		3	II.	37,6 b)	24 b)	16,6 b)	24 b)	16,6 b)	9,2 b)	
			III.	37,6 e)	24 e)	16,6 e)	24 e)	16,6 e)	9,2 e)	
		4	II.	51 b)	36,6 b)	25,4 b)	36,6 b)	25,4 b)	14,2 b)	
			III.							

II. Fig. 470: PTFE- / Pure graphite-packing;

III. Fig. 471: Bellows seal

Air supply pressure max. of pneumatic actuators DP:

max. permissible 6 bar

Air supply pressure max. limit of control valve:

max. permissible a) 5 bar b) 4,5 bar c) 4 bar d) 3,5 bar e) 3 bar

³⁾ Not for perforated plug (presentation ref. to page 24). Kvs-values refer to „Selection STEVI“ in the Technical annex.

Fig. / Plug design	Max. differential pressure drop																
470/471-ANSI	Seat-ø	(inch)	0,12	0,2	0,47	0,71	0,87	0,98	1,26	1,57	1,97	2,56	3,15	3,94	4,92	5,91	7,87
Parabolic plug (post guiding)	Δ Ps	(psi)	580	580	580	580	580	580	580	435	435	218	116	58	29	29	
V-port plug (post and seat guiding)	Δ Ps	(psi)										435	435	363	218	218	174
Perforated plug (post and seat guiding)	Δ Ps	(psi)				580	580	580	580	580	580	580	580	580	580	580	435

Fig. / Plug design	Max. differential pressure drop																
470/471-ANSI	Seat-ø	(mm)	3	5	12	18	22	25	32	40	50	65	80	100	125	150	200
Parabolic plug (post guiding)	Δ Ps	(bar)	40	40	40	40	40	40	40	30	30	15	8	4	2	2	
V-port plug (post and seat guiding)	Δ Ps	(bar)										30	30	25	15	15	12
Perforated plug (post and seat guiding)	Δ Ps	(bar)				40	40	40	40	40	40	40	40	40	40	40	30

Standard-flange dimensions

Flanges acc. to ANSI B16.5

Nominal diameter			1"	1 1/2"	2"	3"	4"	6"	8"
ANSI300	ØD	(in)	4,88	6,12	6,5	8,25	10	12,5	15,0
ANSI300	ØK	(in)	3,5	4,5	5,0	6,62	7,88	10,62	13,0
ANSI300	n x Ød	(in)	4 x 0,75	4 x 0,88	8 x 0,75	8 x 0,88	8 x 0,88	12 x 0,88	12 x 1,0

Nominal diameter			DN 25	DN 40	DN 50	DN 80	DN100	DN150	DN200
ANSI300	ØD	(mm)	124	155	165	210	254	318	381
ANSI300	ØK	(mm)	89	114	127	168	200	270	330
ANSI300	n x Ød	(mm)	4 x 19	4 x 22	8 x 19	8 x 22	8 x 22	12 x 22	12 x 25

Pressure-temperature-ratings acc. to ANSI B16.5

Material			-20°F to 100°F	122°F	212°F	302°F	392°F	482°F	572°F	662°F	752°F	842°F
Fig. 470-ANSI SA216WCB	ANSI300	(psi)	741	727	676	654	635	608	577	545	503	334
			-29°C to 38°C	50°C	100°C	150°C	200°C	250°C	300°C	350°C	400°C	450°C
	ANSI300	(bar)	51,1	50,1	46,6	45,1	43,6	41,9	39,8	37,6	34,7	23

Pressure-temperature-ratings acc. to manufacturers standard

Material			+14°F to 100°F*	122°F	248°F	302°F	392°F	482°F	572°F	662°F	752°F	842°F
Fig. 471-ANSI SA216WCB	ANSI300	(psi)	580	580	580	552	507	464	406	401	345	322
			-29°C to 38°C*	50°C	120°C	150°C	200°C	250°C	300°C	350°C	400°C	450°C
	Stainless steel bellows seal (restricted pressure)	ANSI300	(bar)	40	40	40	38,1	35	32	28	25,7	23,8

Intermediate values for max. permissible operational pressures can be determined by linear interpolation of the given temperature / pressure chart.

* Valve with extended bonnet, studs and nuts made of A4-70 (at temperatures below 14°F / -10°C)

Please indicate when ordering:

- Figure-No.
- Nominal diameter
- Nominal pressure
- Body material
- Plug design
- Kvs-value
- Flow characteristic
- Stem sealing
- Actuator
- Special design / accessories

Example:

Figure 35.470...90, Nominal diameter 4" / DN100, Nominal pressure ANSI300, Body material SA216WCB, Parabolic plug, Cv 185 / Kvs 160, GLP, V-ring unit, ARI-PREMIO 1124 lbf / 5kN.

Dimensions in inch	1 inch Δ 25,4 mm
Dimensions in mm	
Weights in lb	1 lb Δ 0,45 kg
Weights in kg	
Pressures in psig	14,5 psi Δ 1 bar
Pressures in barg	
1 bar Δ 10 ⁵ Pa Δ 0,1 MPa	
Cv in us-gallone/min	0,86 Cv Δ 1 Kvs
Kvs in m ³ /h	

Stem sealing

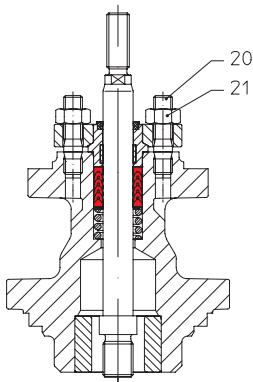

Spring loaded PTFE-V ring packing unit

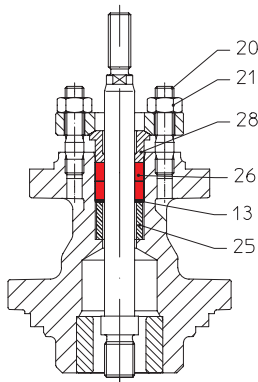

PTFE-/ Pure graphite-packing

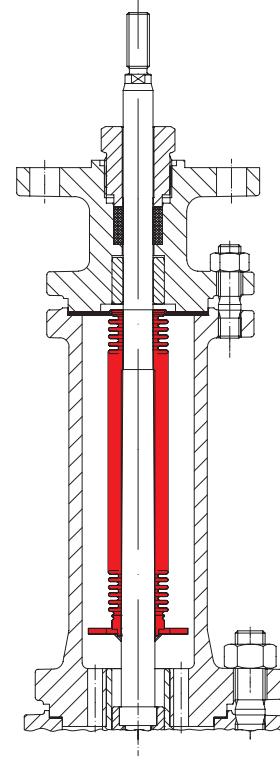

Bellows seal with safety stuffing box

Pos.	Description	
13	Washer *	SA 240 Gr. 304
20	Studs	A4-70
21	Hexagon nuts	A4
25	Distance bush *	SA 276 Gr.420
26	Packing ring *	PTFE or Pure graphite
28	Packing follower *	SA 276 Gr.420

* Spare part

Plug design

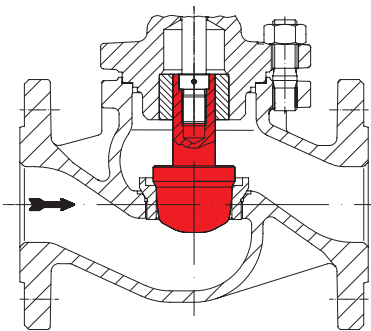

Parabolic plug with post guiding
(1"-6" / DN 25-150)

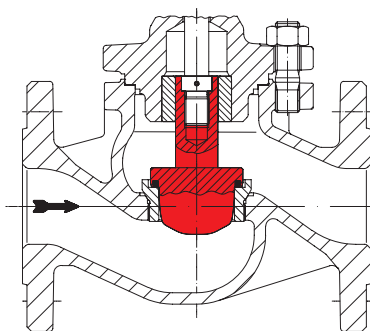

Parabolic plug with PTFE soft seat and post guiding
(1"-6" / DN 25-150)

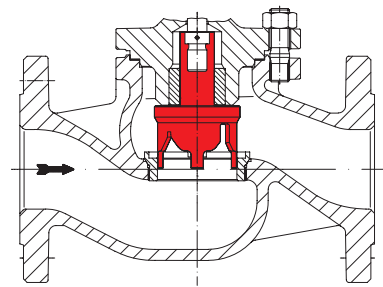

V-port plug with post and port guiding
(Standard at 8" / DN200)

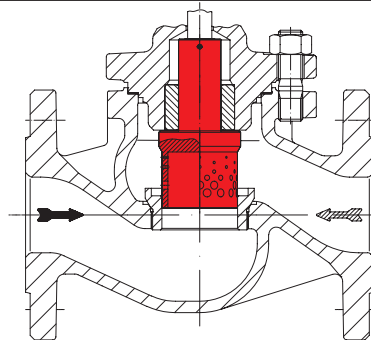

Perforated plug with post and port guiding

➡ Flow direction for gas and steam to reduce the sound level

↗ Flow direction for liquids to reduce the cavitation

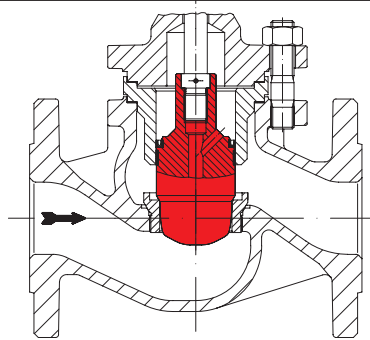

Parabolic pressure balanced plug

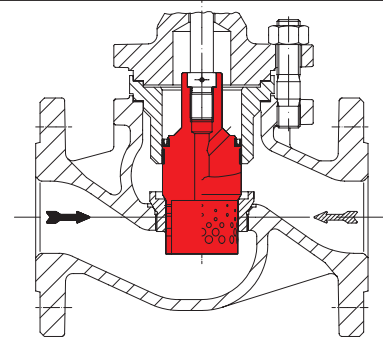

Perforated pressure balanced plug

➡ Flow direction for gas and steam to reduce the sound level

↗ Flow direction for liquids to reduce the cavitation